

Bewegung durch Perfektion | Movement by Perfection

ZIEHL-ABEGG



Die Königsklasse
The Royal League

Die Königsklasse in Lufttechnik, Regeltechnik und Antriebstechnik | The Royal League in ventilation, control and drive technology

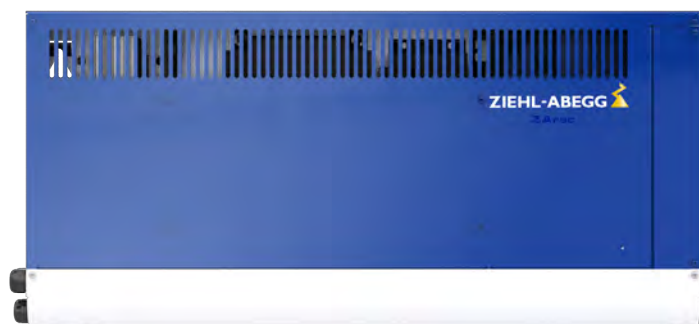

ZA rec 4C

Recuperation unit

Original operating instructions

Store for future use!



Content

1	General information	5
1.1	Validity	5
1.2	Structure of the operating instructions	5
1.3	Target group	5
1.4	Structure of operating instructions	5
1.5	Exclusion of liability	5
1.6	Copyright	5
1.7	Explanation of symbols and designators	6
2	Safety instructions	6
2.1	General	6
2.2	Intended use	6
2.3	Pictographs	6
2.4	Product safety	6
2.5	Requirements placed on the personnel / due diligence	7
2.6	Commissioning	7
2.7	Working on device / Hazards through residual voltage	7
2.8	Modifications / interventions in the device	7
2.9	Operator's obligation of diligence	7
2.10	Employment of external personnel	8
3	Product overview	8
3.1	Service & maintenance	8
3.2	Transport	8
3.3	Disposal / recycling	8
4	Mechanical installation	9
4.1	General notes	9
4.2	Switch cabinet installation	10
4.3	Wall mounting / shaft mounting	10
4.4	Dimensions/minimum clearances	14
5	Electrical installation	16
5.1	EMC-compatible installation	16
5.1.0.1	Contacting the shielding of the DC cable on the ZArec4C 013	17
5.1.0.2	Contacting the shielding of the DC cable and brake resistor cable on the ZArec4C 026/039	17
5.1.0.3	Contacting the shielding of the DC cable on the ZETADYN 3C	17
5.1.0.4	Contacting the shielding of the DC cable on the ZETADYN 3BF	18
5.1.0.5	Contacting the shielding of the DC cable on the ZAdyn4C	18
5.2	Terminal positions	19
5.3	Wiring	20
5.3.0.6	Side	20
5.3.0.7	Underneath	20
5.4	Strain relief	21
5.4.0.8	X-IN-OUT connection cable and ZApad cable strain relief	21
5.4.0.9	Strain relief control voltage cable, DC cable, brake resistance cable, power cable	22
5.4.0.10	Strain relief power line	22
5.4.0.11	Strain relief cable connection X-IN-OUT, ZApad cable and cable connection X-CAN	23
5.5	Protective earth connection	23
5.6	Mains connection (X1)	25
5.7	FI circuit breaker (RCCB)	26
5.8	Control transformer in the mains feed line	26

5.9	External brake resistor (X-BR)	27
5.10	Connecting DC cable (ZArec4C 013: X2 / ZArec4C 026/029: X-DC)	29
	5.10.0.12 Connection	29
5.11	Control voltage (X4) (only in the case of ZArec4C 013)	30
5.12	Digital inputs (X-IN-OUT)	31
	5.12.0.13 Connection	31
5.13	Digital outputs (X-IN-OUT)	32
5.14	Input X-EN_MC (only in the case of ZArec4C 026/039)	32
5.15	Signal timing	33
5.16	Circuit suggestion, ZArec4C and ZAdyn4C	34
5.17	Circuit suggestion, ZArec4C and ZAdyn4C - UPS evacuation	35
5.18	Circuit suggestion, ZArec4C and ZAdyn4C - 3~ evacuation	36
5.19	Circuit suggestion ZArec4C, ZAdyn4C and EVAC 3C	37
6	Accessories	38
6.1	ZApad control terminal	38
7	Operation and parameterising	40
7.1	Possibilities for operation and configuration	40
7.2	Menu navigation	40
8	Start-up	41
8.1	Safety instructions	41
8.2	Switching on the ZArec4C	41
8.3	Configuring the ZArec4C	42
8.4	Parameterisation of the ZAdyn	42
9	Parameter list	42
9.1	LCD & Password menu	42
9.2	Basics	42
9.3	Monitoring menu	43
9.4	Controller menu	43
9.5	Filter menu	43
9.6	Statistic menu	44
9.7	Memory Card menu	44
9.8	MMC-Recorder menu	45
9.9	Power section menu	45
9.10	CAN menu	45
9.11	ZA-Intern menu	45
9.12	INFO menu	46
10	Error diagnosis	47
10.1	General	47
10.2	Acknowledgement	47
10.3	LED	47
10.4	Readout the error memory	47
10.5	Delete error memory	49
10.6	Error list	49
10.7	Message list	51
11	Energy saving	52
12	Special functions	53
12.1	Software update	53
12.2	Parallel operation of two ZArec4C 013	54
12.3	UPS evacuation	55

13	Operating the ZArec4C with the frequency inverters from other manufacturers	55
13.1	Requirements for the frequency inverter	55
13.2	ZArec4C control and evaluation	55
	13.2.0.14 RDY (O3) digital output - operational	56
	13.2.0.15 Digital output /ERR (O4) - errors requiring switching off	56
13.3	Statuses of digital inputs and outputs	57
14	Enclosure	59
14.1	Technical data for ZArec4C	59
14.2	Part no.	60
14.3	Allocation of ZArec4C to ZAdyn / ZETADYN frequency inverter	60
14.4	EU declaration of conformity	61
14.5	Index	63

1 General information

Compliance with the following instructions is mandatory to ensure the functionality and safety of the product. If the following instructions given especially but not limited for general safety, transport, storage, mounting, operating conditions, start-up, maintenance, repair, cleaning and disposal / recycling are not observed, the product may not operate safely and may cause a hazard to the life and limb of users and third parties.

Deviations from the following requirements may therefore lead both to the loss of the statutory material defect liability rights and to the liability of the buyer for the product that has become unsafe due to the deviation from the specifications.

1.1 Validity

This instruction manual applies to:

Recuperation unit of series: ZArec4C 013, 026 and 039
as of software version 4.05

1.2 Structure of the operating instructions

These operating instructions help you to work safely on and with the recuperation unit ZArec4C. They contain safety instructions that must be complied with as well as information that is required for failure-free operation of the recuperation unit.

The operating instructions must be kept at the recuperation unit. It must be ensured that all persons who have to perform activities on the recuperation unit can consult the operating instructions at any time. Instructions for use in accordance with the German Occupational Safety and Health Act and the German Work Equipment Ordinance must be provided in addition to the operating instructions. Keep the operating instructions for continued use. They must be passed-on to all successive owners, users and final customers.

1.3 Target group

The operating instructions address persons entrusted with planning, installation, commissioning and maintenance and servicing and who have the corresponding qualifications and skills for their job.

1.4 Structure of operating instructions

The operating instructions have a systematic structure. The order of the individual chapters corresponds to the order of the work steps for first time installation of the recuperation unit.

The operating instructions contain the following information:

- Device description
- Mechanical and electrical installation
- Operation and parameterising
- Start-up
- Parameter list
- Diagnostic
- Enclosure

1.5 Exclusion of liability

Concurrence between the contents of these operating instructions and the described hardware and software in the device has been examined.

It is still possible that non-compliances exist; no guarantee is assumed for complete conformity. The contents of this manual are put through periodic reviews. Necessary modifications are incorporated into the next version.

ZIEHL-ABEGG SE is not liable for damage due to misuse, incorrect use, improper use or as a consequence of unauthorized repairs or modifications.

1.6 Copyright

These operating instructions contain information protected by copyright. The operating instructions may be neither completely nor partially photocopied, reproduced, translated or put on a data medium without prior explicit consent from ZIEHL-ABEGG SE. Infringements are liable for damages.

All rights reserved, including those that arise through patent issue or registration on a utility model.

1.7 Explanation of symbols and designators

Symbol	Meaning
▷	Instruction. Follow the instructions in sequence in the order described.
✓	Result of an action (result). Here, the result of an action is described.

2 Safety instructions

2.1 General

This chapter contains instructions to prevent personal injury and property damage. These instructions do not lay claim to completeness. In case of questions and problems, please consult our company technicians.

2.2 Intended use





The ZArec4C is a recuperation unit for lift systems with frequency inverters. It serves to feed the energy generated in generator travel into the three-phase current mains of the building in which the lift system is located. The device is not designed for any other use than those listed here – this is considered as improper use.

Reading these operating instructions and complying with all contained instructions – especially the safety instructions contained therein – are considered part of intended use. Furthermore, carrying out all inspection work in the prescribed scheduled intervals is part of intended use

Not the manufacturer, rather the operator of the ZArec4C is liable for any personal harm or material damage arising from non-intended use!

2.3 Pictographs

Safety instructions are highlighted with warning triangles and are depicted according to the degree of hazard as follows.

	Danger! General hazardous area. Death or severe injury or significant property damage can occur if the corresponding precautions are not taken!
	Warning! Risk of moderate or minor injury if the corresponding precautions are not taken!
	Warning! Material damage is possible if the corresponding precautions are not taken!
	Danger! Danger by dangerous, electric voltage! Death or severe injury can occur if the corresponding precautions are not taken!
	Information Important information and advice for user

2.4 Product safety

The device conforms to the state of the art at the time of delivery and is fundamentally considered to be reliable. The device and its accessories must only be used in a flawless condition and installed and operated with compliance to the operating instructions.

Exceeding the limits stated in the “Enclosure / technical data” chapter can lead to a defect in the device.

2.5 Requirements placed on the personnel / due diligence

Persons entrusted with the planning, installation, commissioning and maintenance and servicing in connection with the device must have the corresponding qualifications and skills for these jobs. Based on their training, knowledge and experience as well as knowledge of the relevant standards, they must be able to judge the work transferred to them and be able to recognize possible hazards. In addition, they must be knowledgeable about the safety regulations, EU directives, rules for the prevention of accidents and the corresponding national as well as regional and in-house regulations. Personnel to be trained or instructed and apprentices are only permitted to work on the device under the supervision of an experienced person. This also applies to personnel undergoing general training. Comply with the legal minimum age

2.6 Commissioning



Danger!

During commissioning, unexpected and hazardous conditions can arise in the entire system due to incorrect settings, defective components or incorrect electrical connections

During the commissioning following has to be observed:

- Remove all persons and objects from the hazardous area
- The EMERGENCY-STOP functions must be in working order
- Commissioning is only permitted with compliance to the EMC directive 39/336/EEC

2.7 Working on device / Hazards through residual voltage

Before working on previously installed devices, separate them from the mains and secure them against reconnection.



Danger!

Through use of capacitors, danger of death exists even after switching off the device through directly touching the energized parts or due to parts that have become energized due to faults.

Wait at least **3 minutes** before working on the device.

The safe isolation from the supply must be checked using a **two-pole** voltage detector.



Danger!

It is generally forbidden to carry out work on electrical live parts. Protection class of the device when open is IP 00! It is possible to touch hazardous voltages directly.

2.8 Modifications / interventions in the device

For reasons of safety, no unauthorized interventions or **modifications** may be made on the device . All planned modifications must be authorized by the manufacturer in writing.

Use only genuine spare parts / genuine wearing parts / genuine accessories from the ZIEHL-ABEGG SE. These parts were specifically designed for the device. There is no guarantee that parts from non-original sources are designed and manufactured in correspondence with load and safety requirements.

Parts and special equipment not supplied by the ZIEHL-ABEGG SE are not approved for use.

2.9 Operator's obligation of diligence

The device has been designed and constructed with consideration of a hazard analysis and after carefully selecting the harmonized standards to be complied with as well as additional technical specifications. It thus complies with the state-of-the art and ensures the highest degree of safety. However, this safety can only be implemented in operational practice if all measures necessary for this purpose are taken. The operator of the installation has the obligation of due diligence to plan these measures and monitor their implementation.

In particular, the operator must ensure that

- the device is only used for the purpose for which it was intended
- The installation is operated solely in a flawless, functional condition and that especially the safety devices are periodically checked for their properly functioning condition
- The required personal safety gear is available to and used by the operating, maintenance and repair personnel
- The operating instructions are always readily available at the location where the frequency inverter is being used, are complete and are in legible condition

- Only sufficiently qualified and authorized personnel operate, maintain and repair the device
- these staff receive regular instruction in all relevant occupational safety and environmental protection issues, are knowledgeable about the operating instructions and, especially, are familiar with the safety instructions contained therein.
- all safety and warning notices attached to the device are never removed and remain legible.

2.10 Employment of external personnel

Maintenance and service work are frequently carried out by external employees who often do not recognize the specific situations and the thus resulting dangers.

These persons must be comprehensively informed about the hazards in their area of activity. You must monitor their working methods in order to intervene in good time if necessary.

3 Product overview

3.1 Service & maintenance

These jobs must be completed during the recurrent maintenance work:

- Check the device for dirt and clean if necessary
- Check the connections and tighten if necessary

3.2 Transport

- The device is packed ex factory to suit the transport method previously agreed.
- Always use the original packaging materials when transporting the device
- Avoid shocks and impacts to the device during the transport

3.2.1 Storage duration:

The storage duration depends particularly on the electrolytic capacitors because the oxide coating in the capacitor deteriorates.

Storage duration:

- 12 months at -20 ... +50 °C
- 24 months at -20 .. +45 °C
- 36 months at -20 .. +40 °C

If storage exceeds the stated maximum storage times, you must carry out a reformation of the capacitors before applying the entire mains voltage to the ZArec4C.

New formation:

To reform, the ZArec4C needs to be connected to a ZAdyn connected to reduced voltage (230 VAC at L1 / L2) for approx. 1 hour.

3.3 Disposal / recycling



Disposal must be carried out professionally and in an environmentally friendly way in accordance with the respective national legal stipulations.

- ▷ Separate the materials by type and in an environmentally friendly way.
- ▷ If necessary, commission a specialist company with the waste disposal.

4 Mechanical installation

4.1 General notes

The recuperation unit ZArec4C is a closed compact device, which is developed for wall-mounting in a machine-room or in a lift shaft. It can also be installed in the switch cabinet but adequate cooling must be provided in this case (see chapter "Switch cabinet installation").



Danger!

To avoid a defect in the ZArec4C due to assembly errors or environmental influences, the following points must be complied with during the mechanical installation

Before assembly - ZArec4C 013

- Open the packing of the ZArec4C
- Remove the white and small blue cover of the ZArec4C



Danger!

The large blue cover of the ZArec4C may not be removed because there are bare, live parts inside the ZArec4C. Failure to observe this provision can lead to serious injury.

- Unscrew ZArec4C from the pallet
- Remove the ZArec4C from the packing and check for any transport damage
- Carry out installation only on a clean, level and stable foundation
- Assemble the ZArec4C outside the traffic area

Before assembly - ZArec4C 026/039

- Open the packing of the ZArec4C
- ZArec4C remove from the fastening plate and packaging
- ZArec4C check for possible shipping damage
- Unscrew the fastening plate from the pallet
- Remove the fastening plate from the packaging and check for any possible shipping damage
- Carry out installation only on a clean, level and stable foundation
- Assemble the ZArec4C outside the traffic area

During installation

- Mount the device in a torsion free conditions
- ZArec4C 013 installation position: horizontal
- ZArec4C 026/039 installation position: vertical, connection terminals (X1, X2) at bottom; no horizontal mounting
- Assemble ZArec4C without tension
- Prevent drilling chips, screws and other foreign bodies from reaching the interior of the ZArec4C
- Maintain the stated minimum clearances to ensure unobstructed cooling- air feed as well as unobstructed outgoing air discharge (see fig. "Minimum clearances")

Ambient conditions

- Mounting the ZArec4C on vibrating components is not allowed
- Do not expose ZArec4C to any shock influences
- Prevent humidity
- Avoid aggressive and conductive materials in the environment

4.2 Switch cabinet installation

CAUTION!

Warning!

ZArec4C is designed for wall mounting in the machine room or lift shaft. Adequate cooling must be ensured for assembly in the switch cabinet. The power loss of the ZArec4C (see chapter "Technical Data") must be taken into account here.

The specified installation position and the minimum distances must be observed when assembling in the switch cabinet.

4.3 Wall mounting / shaft mounting

4.3.1 ZArec4C 013

The ZArec4C is mounted on a wall or in a shaft using a 4-point fastening. The ZArec4C 013 is to be mounted in a horizontal installation position.

▷ Mark the positions of the fastening points (see fig.). See the dimension drawings in the "Mechanical Installation / Dimensions / Minimum Clearances" chapter for the distances between the fastening points.

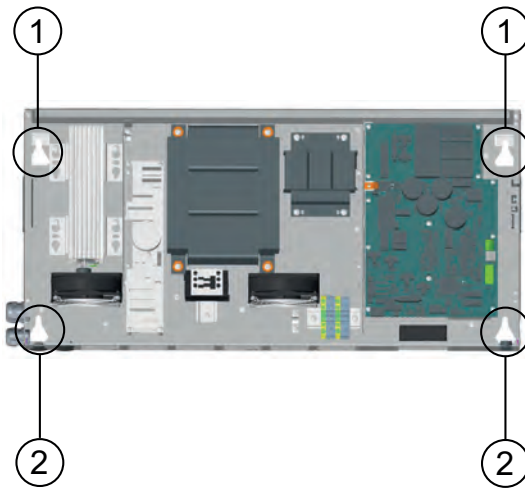

Fastening points

- 1 upper fastening points
- 2 Lower fastening points

- ▷ Drill fastening holes.
- ▷ Attach fastening screws for the fastening points.
- ▷ Hang ZArec4C on the fastening points.

4.3.2 ZArec4C 026/039

The ZArec4C 026/039 is mounted on a wall or in a shaft using a fastening plate. The ZArec4C 026/039 is to be mounted in a vertical installation position.

- ▷ Loosen and remove the safety screws (1).
- ▷ Remove the ZArec4C 026/039 from the fastening plate (2).

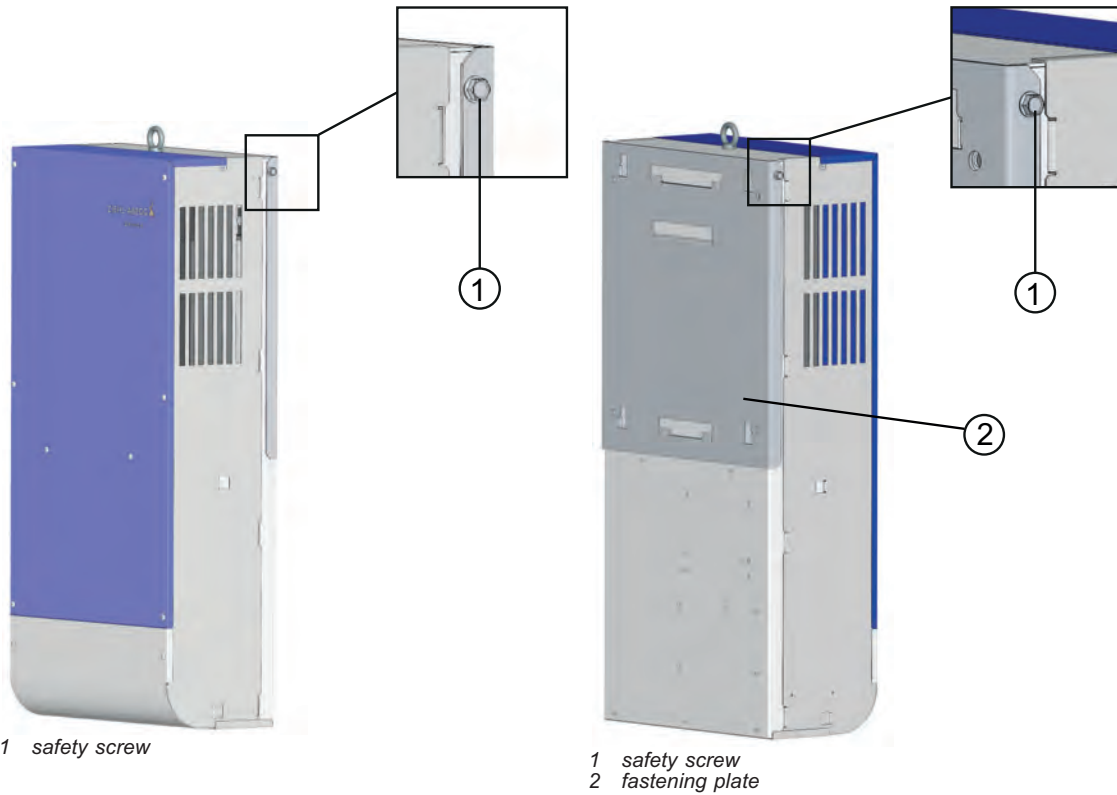

- ▷ Trace the positions of the fastening points (3) of the fastening plate. See the dimension drawings in the chapter "Mechanical Installation/Dimensions/Minimum Clearances" for the distances between the fastening points.

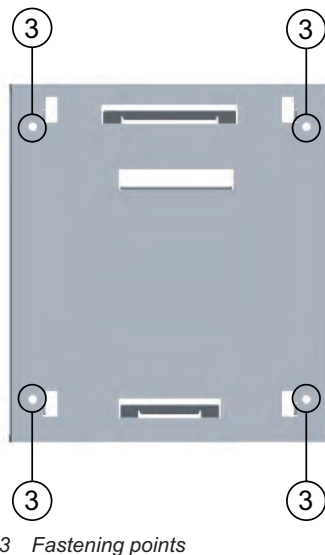

- ▷ Drill fastening holes.
- ▷ Screw on the fastening plate. Use suitable fasteners for this purpose.
- ▷ Suspend ZArec4C 026/039 on the fastening plate.

- The 90° folds on the ZArec4C 026/039 (4) and the fastening plate (5) are laid on top of one another.
- The straps (6) on the ZArec4C 026/039 reach in the openings in the folds (7) of the fastening plate.
- The fastening plate hooks (8) reach in the recesses (9) on the back of the ZArec4C 026/039.

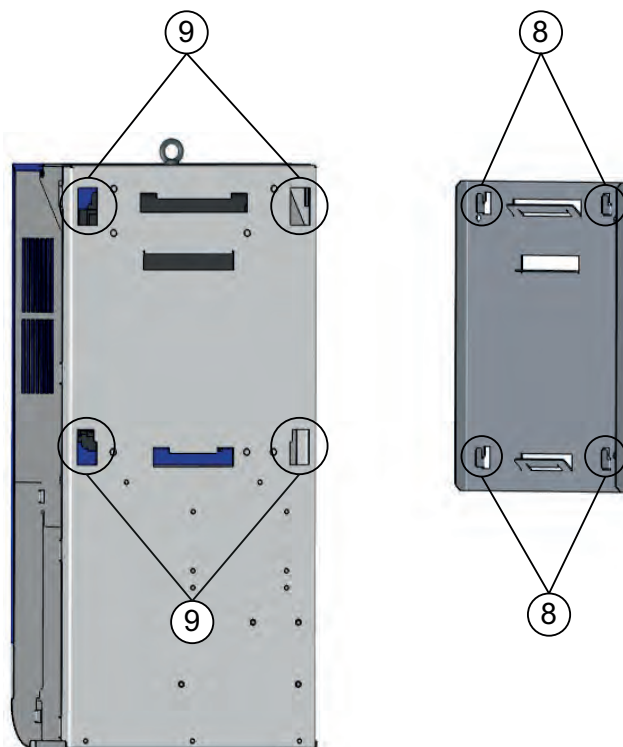
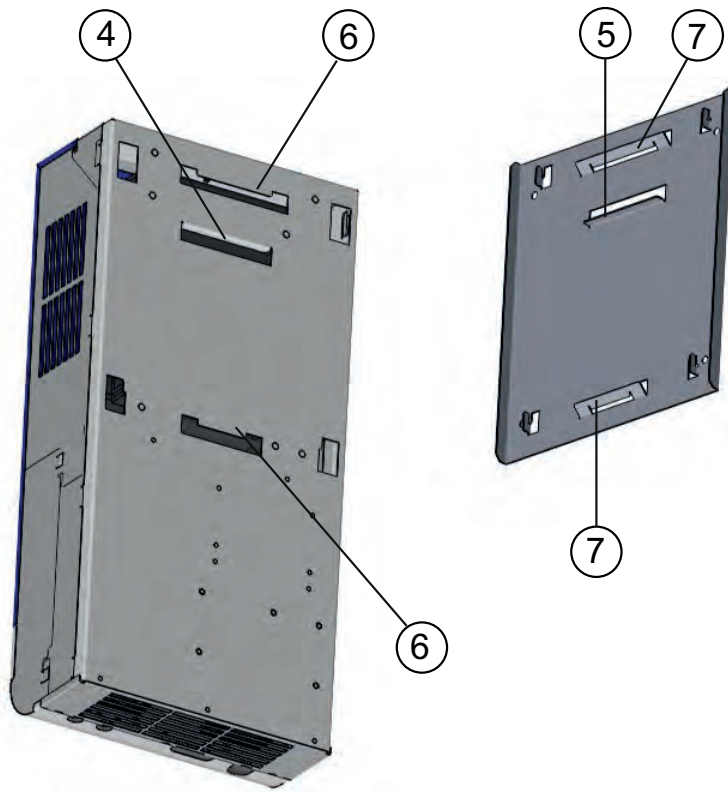

Push back the ZArec4C when suspending it on the fastening plate, until it presses against the fastening plate and the upper edges of the ZArec4C and of the fastening plate are flush with one another.

When suspending the ZArec4C 026/039, make sure that the holes for the safety screws in the fastening plate and in the ZArec4C 026/039 are aligned correctly.

▷ Screw the two safety screws into the provided screw holes.

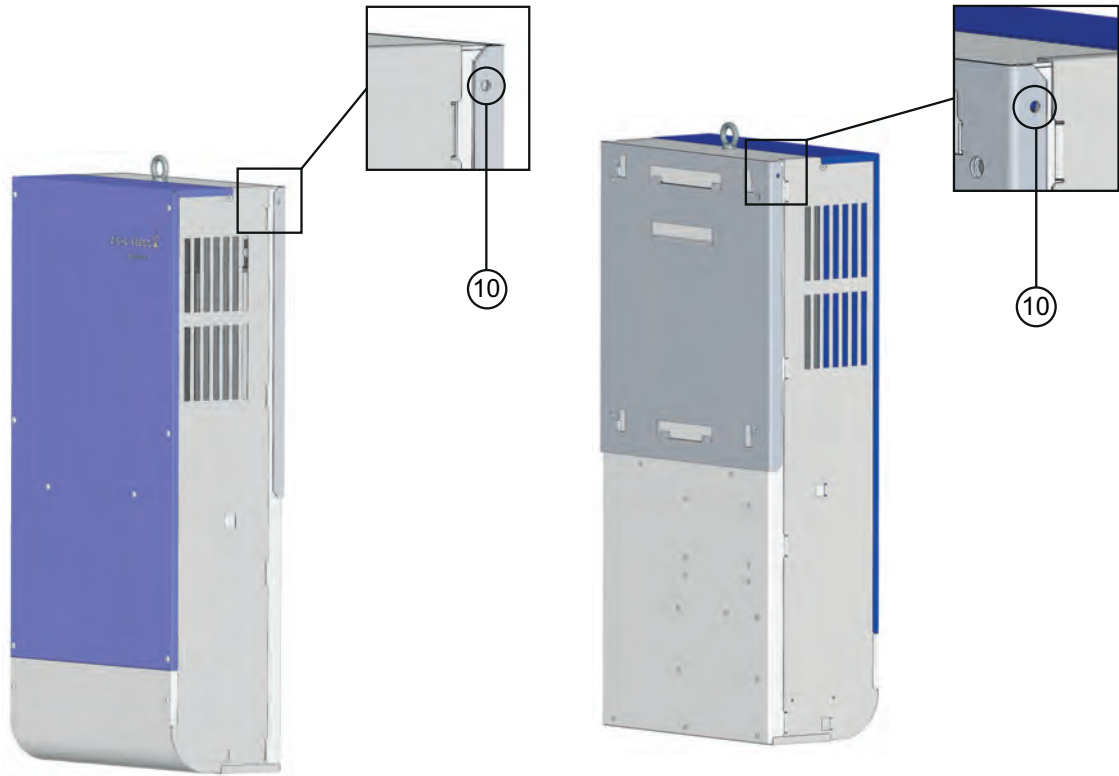

4.4 Dimensions/minimum clearances

4.4.1 ZArec4C 013

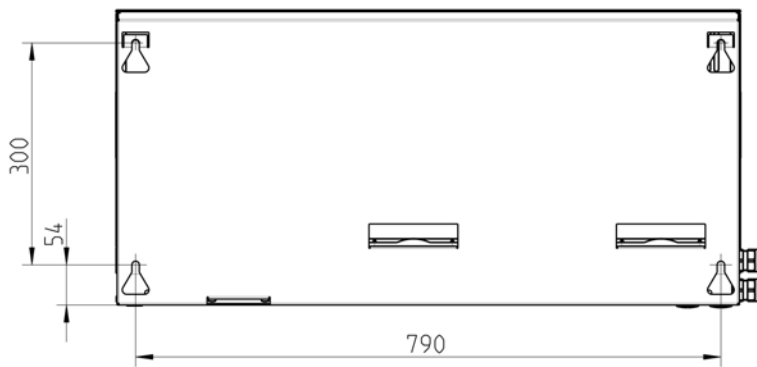
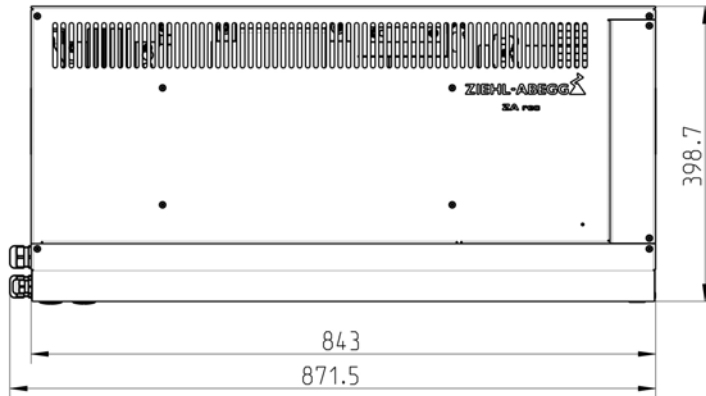
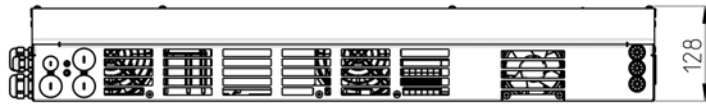

ZArec4C 013 dimensions

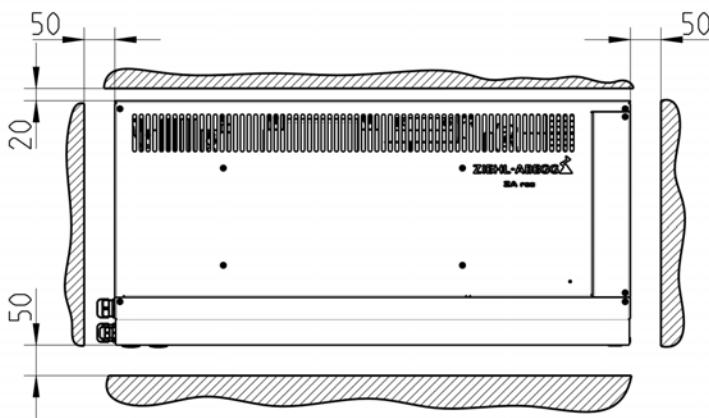

ZArec4C 013 minimum clearances

ZDRE01M0

4.4.2 ZArec4C 026/039

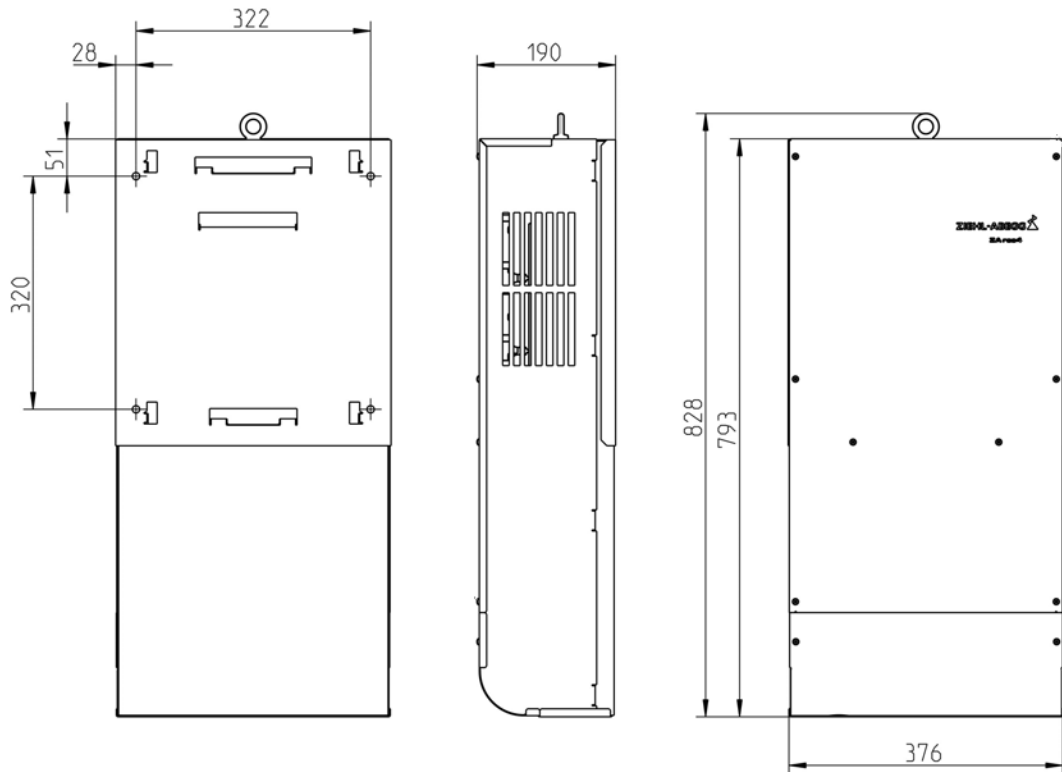

ZArec4C 026/039 dimensions

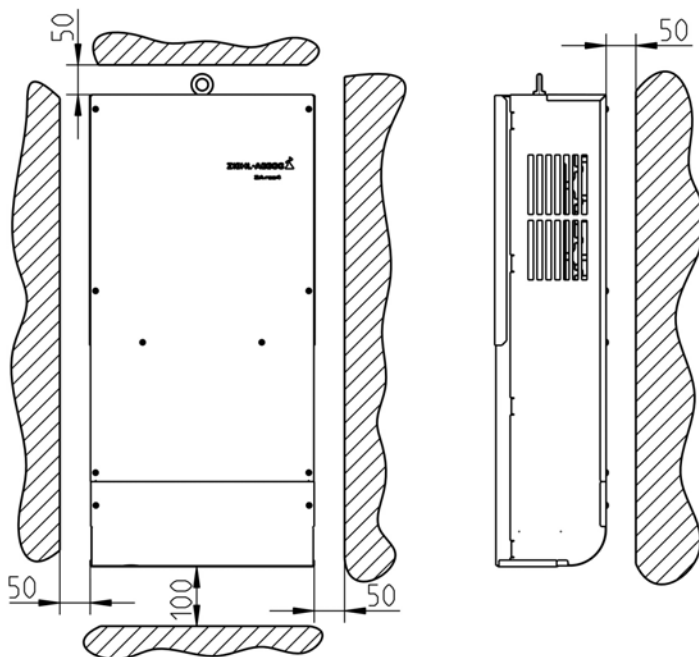

ZArec4C 026/039 minimum clearances
 ZDRE02M0

5 Electrical installation



Danger!

It is forbidden to carry out work on electrically live ZArec4C.
Even after disconnection, the DC-link (terminals X2: +DC / X2: -DC) are still live.
Wait at least 3 minutes before working on the device



Danger!

It is not permitted to operate the ZArec4C with the housing covers removed, as exposed live parts are present inside the ZArec4C. Failure to observe this provision can lead to serious injury.



Warning!

Parts can be destroyed by electrostatic discharge.
Discharge yourself by suitable action before working on electrical components (connectors, etc.). You can do this, for example, by touching earthed metal parts.

Work on electric components may only be carried out by trained electricians or by persons instructed in electricity under the supervision of an electrician in accordance with electrical engineering regulations.

A second person must always be present when working on energized parts or lines who disconnects in case of emergency.

Electrical equipment must be checked regularly: Loose connections are to be re-tightened and damaged lines or cables must be replaced immediately.
Always keep switch cabinets and all electrical supply facilities locked. Access is only allowed for authorized persons using a key or special tool.

Never clean electrical equipment with water or similar liquids.

5.1 EMC-compatible installation

When correctly installed (see below), the ZArec4C corresponds to the following standards:

- EN 12015:2004 Electromagnetic compatibility – Product family standard for lifts, escalators and moving walks – Emission
- EN 12016:2004 + A1:2008 Electromagnetic compatibility – Product family standard for lifts, escalators and moving walks – Immunity

The following points must be observed if the above mentioned standards are to be adhered to:

- Only use shielded cables for connecting the intermediate circuit
- Wind unshielded cables of the brake resistor type BR14-A around the included toroidal core (see figure in the chapter "Electrical Installation / External Brake Resistor (X-BR)")
- If an interruption in the shield is necessary, the shield must then be continued with as low an HF impedance as possible
- Use only shielded control cables
- The shielding of power cables (brake resistance cable, DC cable) must be connected to ground on both sides
- The shielding of control cables (input and outputs) must be connected to ground on the inverter side
- Use shielded lines in the switching cabinet also
- Do not twist shielding for connections; use a suitable shield connection system
- Run the control cables and the encoder cables separate from the power cables
- provide connected inductances (contactors) with suppressors

5.1.1 DC cable and brake resistor cable

5.1.1.1 Contacting the shielding of the DC cable on the ZArec4C 013

On the ZArec4C 013, the shielding of the DC cable must be connected to the earth potential with the clip provided (see fig.).

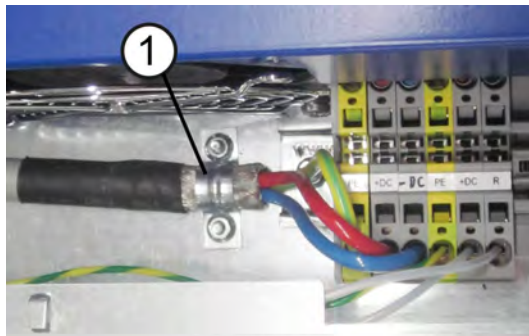

1 Clip

5.1.1.2 Contacting the shielding of the DC cable and brake resistor cable on the ZArec4C 026/039

On the ZArec4C 026/039, the shieldings of the DC cable and brake resistor cable must be connected to the earth potential with the clip provided (see fig.).

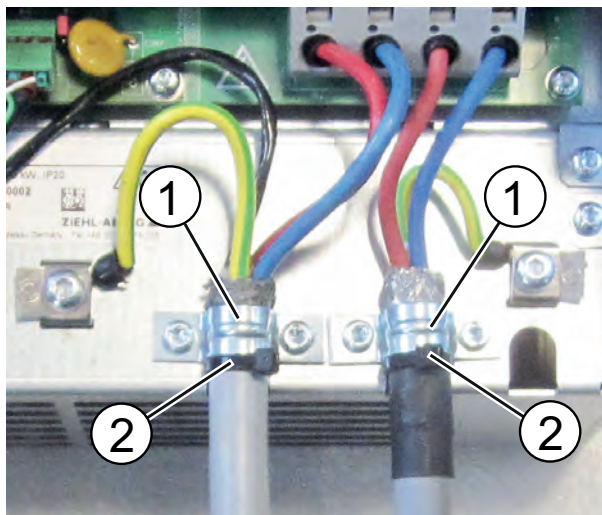

1 Clip
 2 Cable tie for strain relief

5.1.1.3 Contacting the shielding of the DC cable on the ZETADYN 3C

1. Remove the insulation of the DC cable over a length of 160 mm.
2. Cut shielding braid to length up to 40 mm.
3. Arrange shielding braid as shown in the figure.

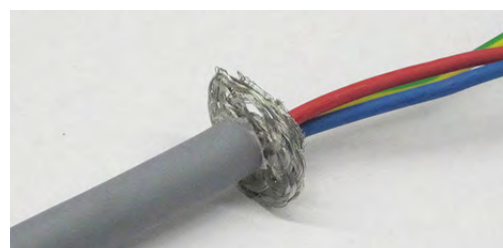
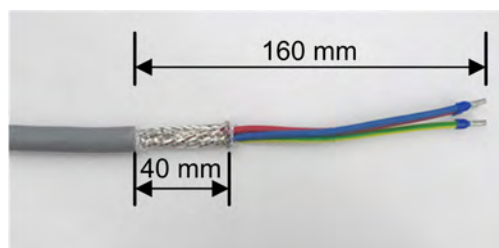

The cable shield for the DC cable must be placed on the ZETADYN 3C with the EMC cable screw glands (see the operating instructions of the ZETADYN 3C).

5.1.1.4 Contacting the shielding of the DC cable on the ZETADYN 3BF

The shielding braid of the DC cable must be connected to the protective ground connection of the ZETADYN 3BF.

1. Remove the insulation of the DC cable over a length of 160 mm.
2. Twist the shielding braid and attach ring cable lug.
3. Connect shielding braid to the protective earth connection of the ZETADYN 3BF.

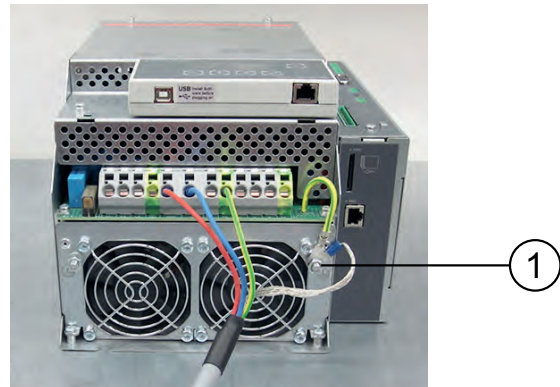
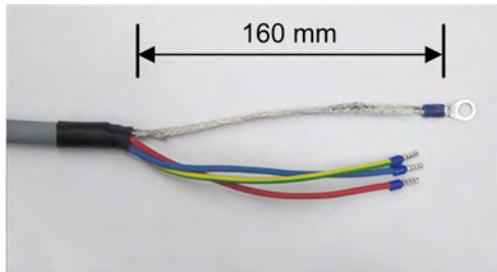

1 Protective earth connection

5.1.1.5 Contacting the shielding of the DC cable on the ZAdyn4C

On the ZAdyn4C, the shielding of the DC cable must be connected to the earth potential with the clip provided (see fig.).

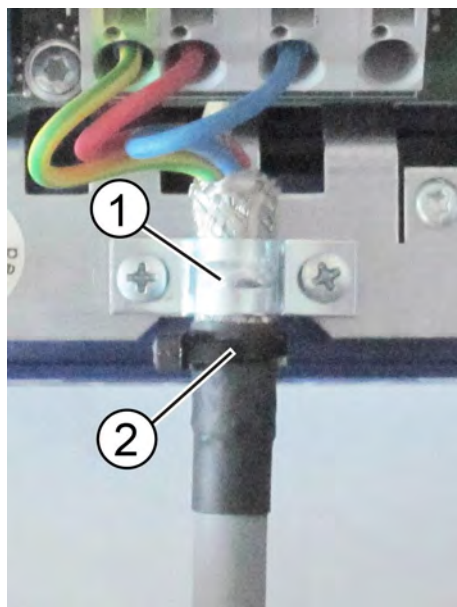

ZAdyn4C 011-032
 1 Clip
 2 Cable tie for strain relief

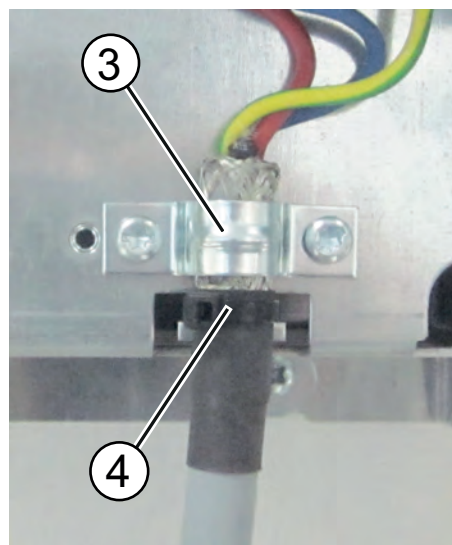

ZAdyn4C 040-074
 3 Clip
 4 Cable tie for strain relief

5.2 Terminal positions

5.2.1 ZArec4C 013

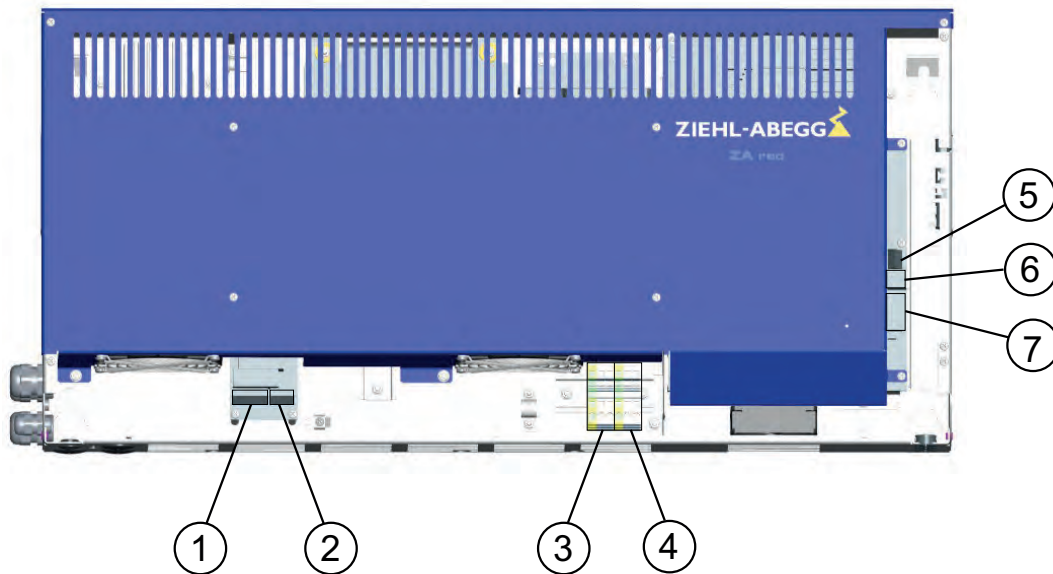

Terminal positions

- 1 X1 line
- 2 X4 control voltage
- 3 X2 connection intermediate circuit ZAdyn
- 4 BR-ext connection external brake resistance
- 5 X-CAN CAN (not supported at the moment)
- 6 X-PAD ZApad
- 7 X-IN-OUT digital inputs, digital outputs

5.2.2 ZArec4C 026/039

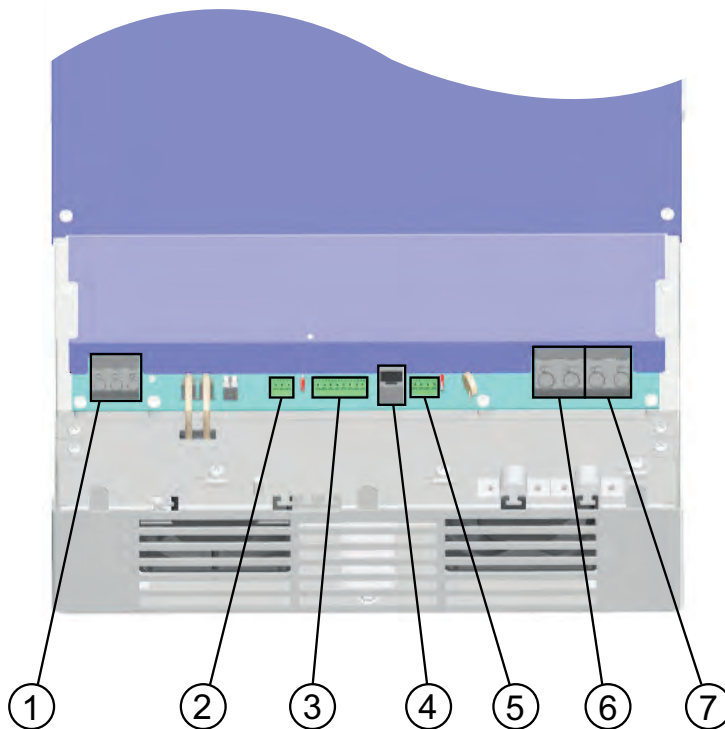

Terminal positions

- 1 X1 line
- 2 X-BC connection temperature monitor brake resistor
- 3 X-IN-OUT digital inputs, digital outputs
- 4 X-PAD ZApad
- 5 X-CAN CAN (not supported at the moment)
- 6 X-BR connection external brake resistor
- 7 X-2 connection intermediate circuit ZAdyn

5.3 Wiring

The ZArec4C is fitted with recesses and cable breakthroughs to feed the different lines into the ZArec4C. The table and figures below show their allocation and positions.

5.3.1 Cable breakthrough of ZArec4C 013

The cables can be fed into the ZArec4C either from the side or from underneath. The cable glands are to be mounted as required.

Control voltage cable, DC cable, brake resistance cable, power cable	Openings on left
X-IN-OUT cable, X-CAN cable, X-PAD cable	Recess or openings on right

5.3.1.1 Side

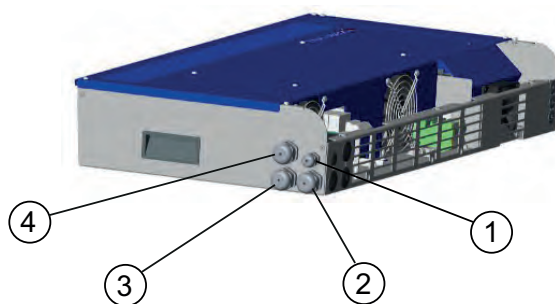

Cable laying left side
 1 Control voltage cable
 2 Brake resistor cable
 3 DC cable
 4 Power line

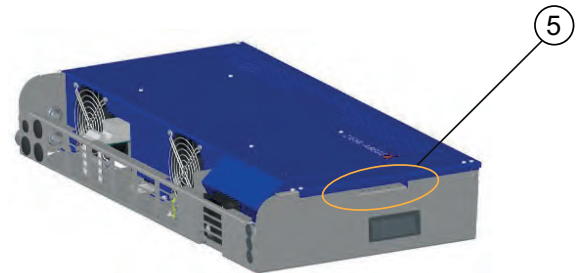

Cable laying right side
 5 X-IN-OUT cables, X-CAN cable, X-PAD cable in any order

5.3.1.2 Underneath

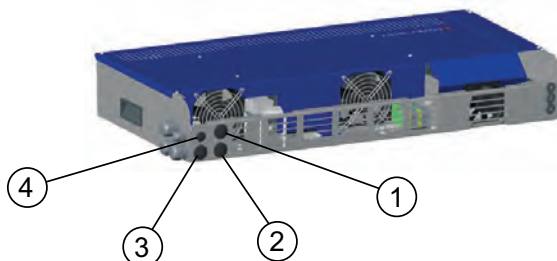

Cable laying left side
 1 Power line
 2 Brake resistor cable
 3 DC cable
 4 Control voltage cable



Cable laying right side
 5,6,7 X-IN-OUT cables, X-CAN cable, X-PAD cable in any order

5.3.2 Cable breakthrough of ZArec4C 026/039

Power line	Opening on left
Cable digital inputs and outputs, cable temperature monitor brake resistor	second opening on left
Brake resistor cable	second opening on right
DC cable	Opening on right

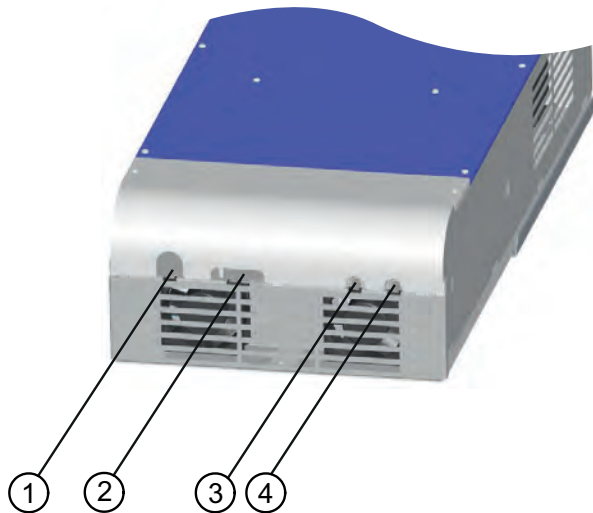

Cable breakthrough of ZArec4C 026/039

- 1 Power line
- 2 Cable digital inputs and outputs, cable temperature monitor brake resistor
- 3 Brake resistor cable
- 4 DC cable

5.4 Strain relief

5.4.1 ZArec4C 013

5.4.1.1 X-IN-OUT connection cable and ZApad cable strain relief

Strain relief by cable ties must be provided on the X-IN-OUT connection cable and the ZApad cable (see fig.).

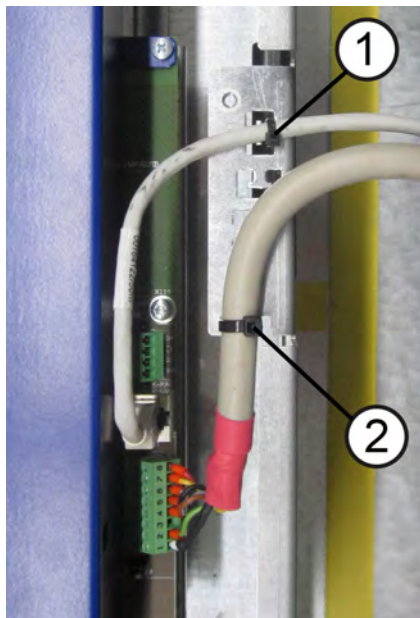

1.2 Strain relief by cable ties

5.4.1.2 Strain relief control voltage cable, DC cable, brake resistance cable, power cable

Strain relief must be provided on the control voltage cable, the DC cable, the brake resistance cable and the DC cable by screw cable glands (see fig.).

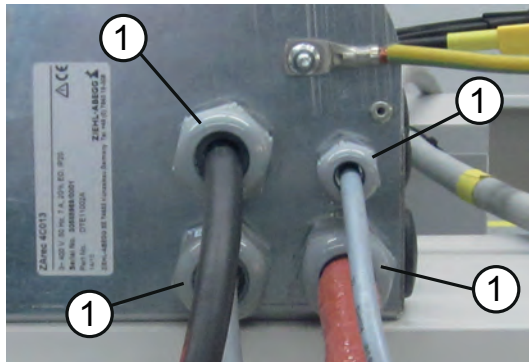

1 Cable gland

5.4.2 ZArec4C 026/039

5.4.2.1 Strain relief power line

A cable tie must be attached to the power line for strain relief (see fig.).

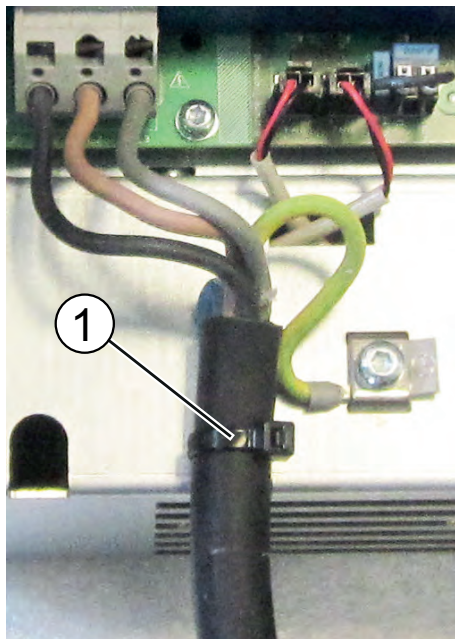

1 Strain relief by cable ties

5.4.2.2 Strain relief cable connection X-IN-OUT, ZApad cable and cable connection X-CAN

Strain relief by means of cable ties must be provided on the X-IN-OUT connection cable, the ZApad connection cable and the X-CAN connection cable (see fig.).

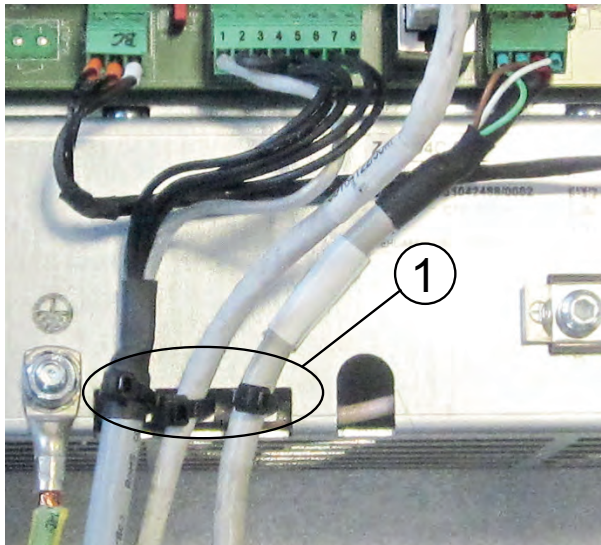

1 Strain relief by cable ties

5.5 Protective earth connection

The ZArec4C has a leakage current > 3.5 mA according to the defined networks in DIN EN 60990 and must therefore be permanently connected. In accordance with EN 50178 item 5.2.11 and 5.3.2.1, the PE conductor connection must have a cross-section of at least 10 mm². In the case of PE conductors < 10 mm², an additional PE conductor must be connected. The cross-section must correspond at least to the cross-section of the PE conductor on the power line.

5.5.1 ZArec4C 013

There are M6 press-in nuts on the ZArec4C 013 to connect the PE conductor.

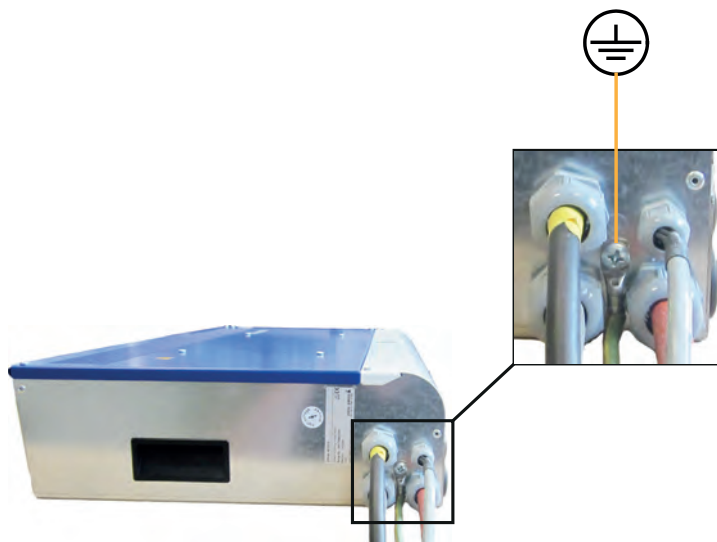

PE conductor connection of ZArec4C 013 on the side

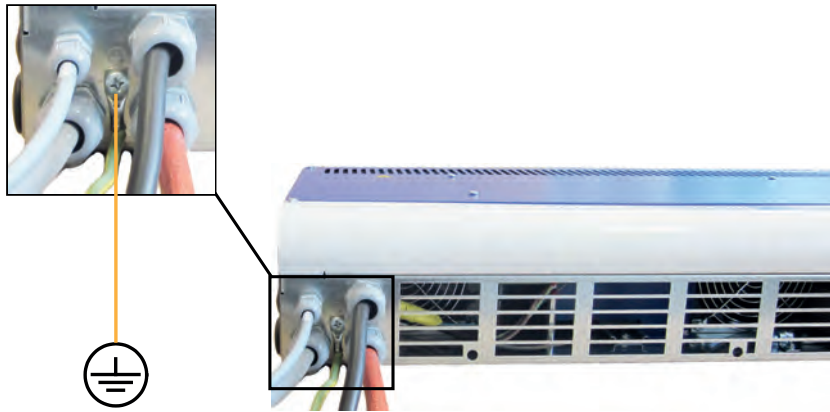

PE conductor connection of ZArec4C 013 underneath

5.5.2 ZArec4C 026/039

The ZArec4C 026/039 has an M6 earthing bolt to connect the PE conductor.

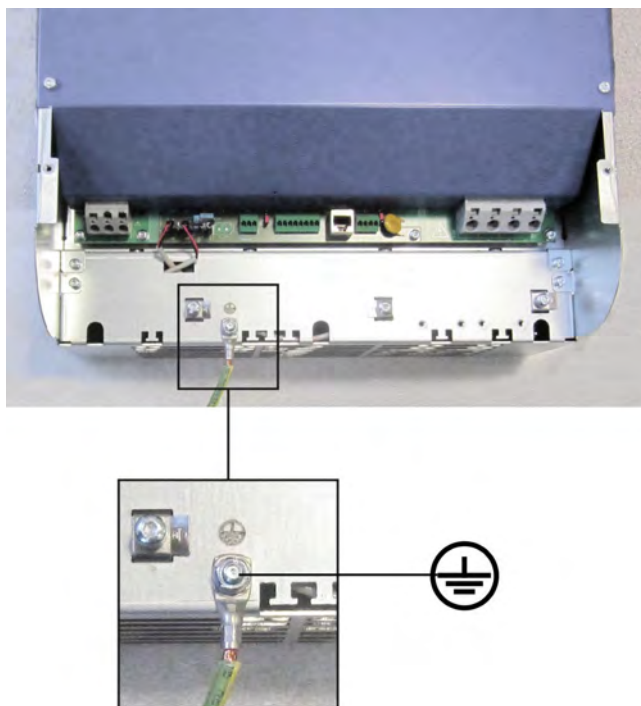

PE conductor connection of ZArec4C 026/039

5.6 Mains connection (X1)



Danger!

Before connecting to the mains, check if the technical data on the ZArec4C rating plate corresponds to the required connection values.

5.6.1 Network form

The mains filter and ZArec4C are designed for use in an earthed supply system. Permissible mains forms are:

- TN network
- TT network



Information

The ZArec4C is unsuitable for use in the IT network!

5.6.2 Lead

- Installation cable (e.g. NYM-J installation cable)
- Cable must not be shielded

5.6.3 Mains fuse

- The fuse protection is implemented in accordance with the line cross-section used

5.6.4 Type of cable

- Both rigid and flexible lines can be utilized. The use of wire-end sleeves is recommended for flexible lines.
- The mains line does not have to be shielded.

5.6.5 Connection

- Connect right hand rotary field to connection terminal X1.
- The mains connection is designed with spring contact terminals. To avoid damage to the connection terminals and to ensure a safe contact, a suitable screwdriver must be inserted into the terminals as far as it will go to fully open them when connecting cables.
- The PE conductor is connected to the housing by the clip next to the connecting terminal X1 (see fig.).

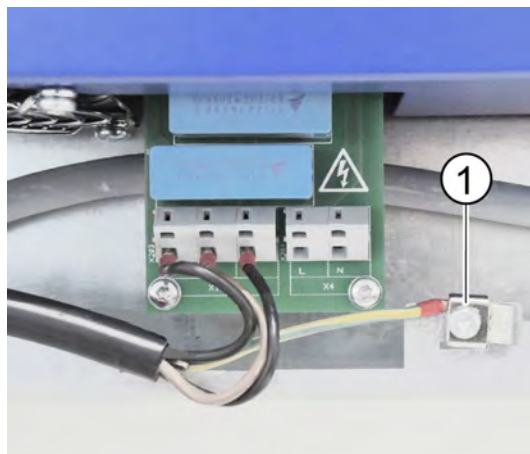

ZArec4C 013
1 Clip PE conductor connection power line

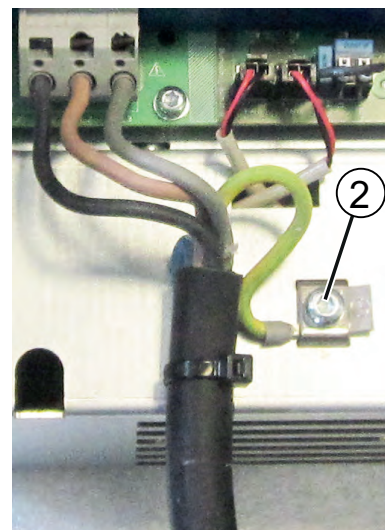

ZArec4C 026-039
2 Clip PE conductor connection power line

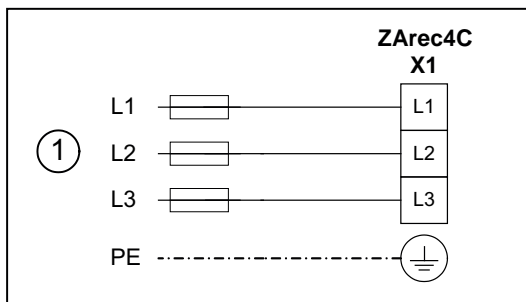

ZArec4C mains connection
 1 Mains 3~ 400 V/PE/50 Hz

5.7 FI circuit breaker (RCCB)



Information

Operation with FI circuit breakers (RCCB) is not possible due to leakage currents.

5.8 Control transformer in the mains feed line

CAUTION!

Warning!

When using a control transformer in the power line of the ZArec4C, you must connect a capacitor parallel to the transformer's primary winding (see fig.).

The capacitor serves to avoid an extreme voltage increase in the event of a voltage cut in one of the phases to which the transformer is connected. This voltage increase can lead to the destruction of the line filter. The cause of this voltage increase is a resonance of the control transformer with the radio interference components, which are always used for power feedback units.

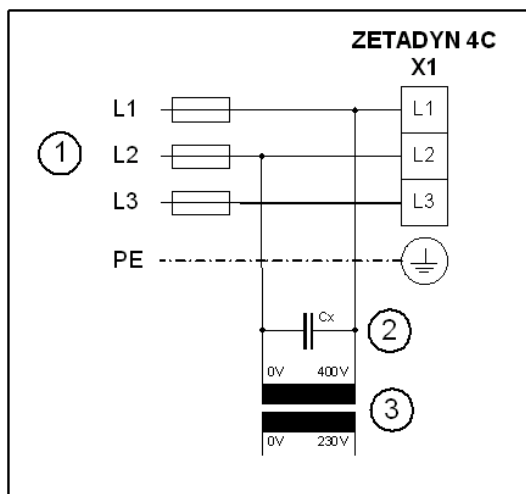

Control transformer in the mains feed line
 1 Mains 3~ 400 V/PE/50 Hz
 2 Capacitor
 3 Control transformer

Recommended capacitor types for Cx:

- Epcos Typ B2583210µF/640V-AV
- Capacitors for motor start-up with the following data: 10 µF/450 VAC

In addition, you must comply with the following:

- During sequential disconnection, switch off the phase on which the transformer is operated last
- Do not oversize the transformer
- If a loaded and an intermittently unloaded transformer is operated in the open loop control, operate these on the same phases

5.9 External brake resistor (X-BR)

The ZArec4C should generally be operated in combination with a brake resistor.

ZArec4C 013:

- Resistor BR11 integrated into the device

ZArec4C 026/039:

- An external brake resistor must be connected



Information

Where required, an external brake resistor must always be connected to the ZArec4C and not to the ZAdyn. This also applies when using an EVAC or UPS. Connecting an external brake resistor to the ZAdyn is not permitted in combination with a ZArec4C.

5.9.1 ZArec4C - ZAdyn - brake resistor allocation

ZArec4C	ZAdyn	max. size, brake resistor	Article no., brake resistor
ZArec4C 013	ZAdyn4C 011-032 ZAdynpro 011 - 032	BR11-A (integrated in ZArec4C 013)	
ZArec4C 026 ZArec4C 039	ZAdyn4C 011-032 ZAdynpro 011 - 032 ZAdyn4C 040 - 074	BR14-A	357195
		BR14-A	
		BR17-3	357216
		BR25-3	357217
		BR50-3	357218



Danger!

Burning out of brake resistor

Personal injury and property damage may occur.

- ▷ If you use a BR17-3, BR25-3 or BR50-3 in combination with a ZArec4C 026/039 and a ZAdyn4C or ZAdynpro 011-032, this can lead to burning out of the brake resistor. Only use the BR14-A if you use a ZArec4C 026/039 and a ZAdyn4C or ZAdynpro 011-032.

5.9.2 Cable length

- maximum line length: 5 m
- When lines over >5 m are used, compliance with **DIN EN 12015** (electromagnetic compatibility – electrical interference) and **DIN EN 12016** (electromagnetic compatibility – noise immunity) is no longer guaranteed.

5.9.3 Brake resistor BR14-A

The brake resistor of the type BR14-A is equipped with prefabricated cables. These must be wound around the delivered toroidal core (see fig.).



Toroidal core BR14-A

5.9.4 Configuring the ZArec4C

CAUTION!

Warning!

Overheating of the brake resistor

If a wrong brake resistor is configured in the menu **Basic settings/BR_TYP**, this can destroy the brake resistor used.

▷ Configure the brake resistor used in the **Basic settings/BR_TYP** parameter.

```

Basic settings
↳ BR_TYP Off
    ↳ BR14
BR - Type
    
```

5.9.5 Connection brake resistor

CAUTION!

Warning!

Overheating of the brake resistor

The brake resistor can burn out in case of a fault.

▷ You must connect an available temperature monitor to the ZArec4C 026 and ZArec4C 039.

CAUTION!

Warning!

Overheating of the brake resistor

When connecting a brake resistor to the +DC and -DC terminals of the X2 connection terminal, this is directly connected to the intermediate circuit of the ZArec4C. This can destroy the brake resistor.

▷ Connect the brake resistor to the R+ and R- terminals (in the case of ZArec4C 026-039).



Information

- The brake resistor of the BR14-A type has no temperature monitor.
- If a BR14-A is connected to a ZArec4C 026/039, the temperature monitor must be bridged at the X-BC connection terminal.

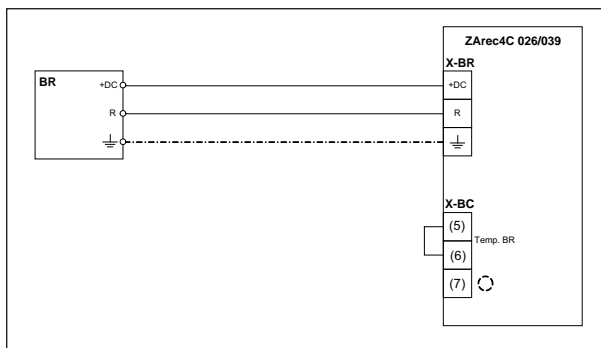

Connecting BR14-A to ZArec4C 026/039

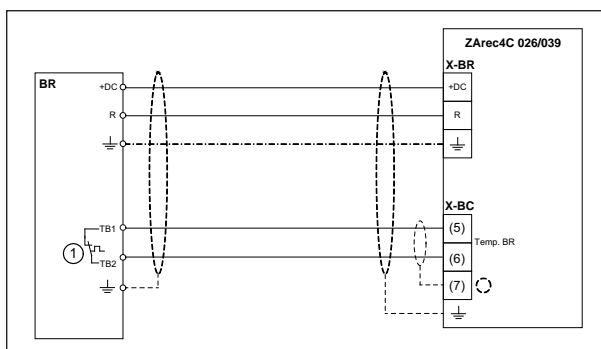

Connecting BR25/BR50

In the case of the ZArec4C 026/039, the PE conductor is connected via the clip next to the X-BR connection terminal on the housing (see fig.).

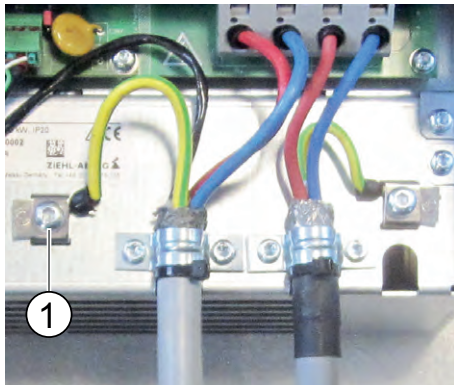

1 Clip PE conductor connection ZArec4C 026/039

5.10 Connecting DC cable (ZArec4C 013: X2 / ZArec4C 026/029: X-DC)

CAUTION!

Warning!

An incorrect connection at the +DC and -DC terminals on the ZArec4C or the ZAdyn can destroy the ZArec4C or the ZAdyn.

CAUTION!

Warning!

In devices of the ZETADYN 3C type only the connecting cables +DC (red) and R (blue) are connected to the terminal X2!

If the ZArec4C is used in connection with devices of the ZETADYN 3C type, the **blue wire** must be rewired from the connection terminal **R** to the connection terminal **-DC** on the internal ZETADYN 3BF!

5.10.1 Type of cable

- Shielded cables must be used. The shieldings must be connected to the shield connection (clip) next to the X2 or X-DC terminal.
- It is recommended to use the pre-assembled connection cable LS-ZArec4C-xx-HX-xx-ZA3/4.

Type	Cable cross section
ZAdyn 011-023	2,5 mm ²
ZAdyn 032-074	6,0 mm ²

5.10.2 Cable length

- maximum line length: 5 m
- When lines over >5 m are used, compliance with **DIN EN 12015** (electromagnetic compatibility – electrical interference) and **DIN EN 12016** (electromagnetic compatibility – noise immunity) is no longer guaranteed.

5.10.2.1 Connection

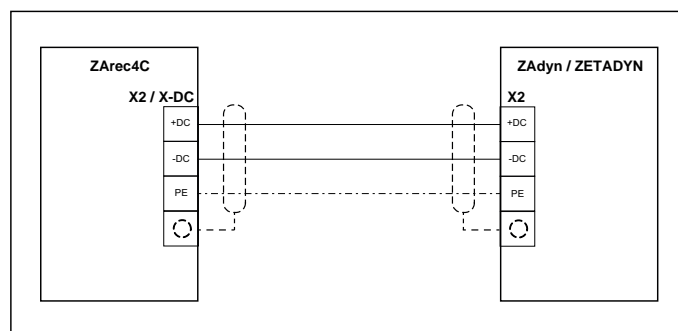

Connecting DC cable to frequency inverter type ZAdyn / ZETADYN

On the ZArec4C 026/039, the PE conductor is connected via the clip next to the X-DC connection terminal on the housing (see fig.).

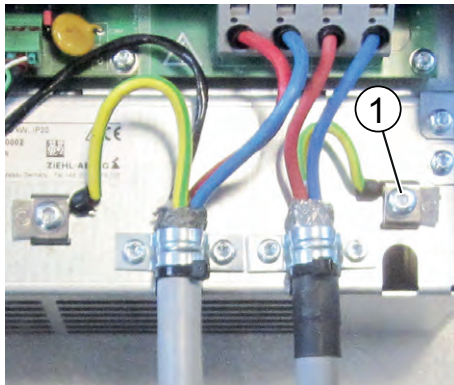

1 Clip PE conductor connection ZArec4C 026/039

5.11 Control voltage (X4) (only in the case of ZArec4C 013)

The control voltage serves to supply the line contactor K1 and the two internal fans. It must be ensured that the control voltage is also switched off in the event of a power failure to make sure that the supply network is disconnected. This also applies for operation in connection with a UPS.

5.11.1 Lead

- Installation cable (e.g. NYM-J installation cable)
- Cable must not be shielded

5.11.2 Mains fuse

- The fuse protection is implemented in accordance with the line cross-section used

5.11.3 Technical data

Voltage range	230 V
Current consumption	< 1 A

5.11.4 Connection

- The connection is designed with spring contact terminals. To avoid damage to the connection terminals and to ensure a safe contact, a suitable screwdriver must be inserted into the terminals as far as it will go to fully open them when connecting cables.
- The PE conductor is connected to the housing by the clip next to the connecting terminal X1.

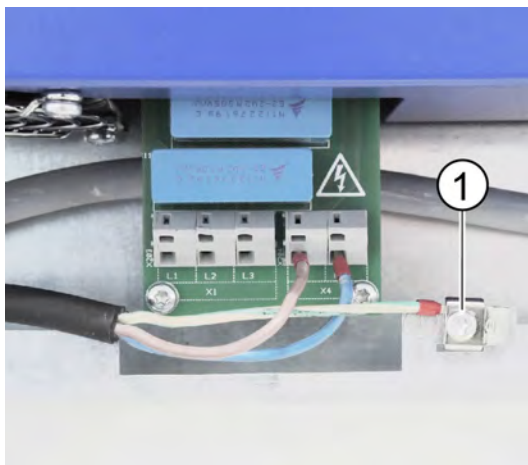

1 Clip PE conductor connection cable control voltage ZArec4C 013

5.12 Digital inputs (X-IN-OUT)

For activation of the ZArec4C, a digital input is available at the X-IN-OUT connection terminal. The input is activated by using the internal 24V control voltage of the ZArec4C (see circuit suggestions in the "Electrical Installation" chapter).

5.12.1 Function of inputs

Input	Function	Explanation
EN	Enable	Activation of the ZArec4C
CL	adjustable	see parameter "f_CL" in chapter "Parameter list / Basics"



Information

The internal 24 V supply is only provided for the digital input. Switching consumers with this voltage is not permitted!

5.12.2 Lead

- Shielded cables must be used. The shieldings must be connected to the shield connection of the X-IN-OUT terminal.
- It is recommended to use the pre-assembled connection cable LS-ZArec4C-xx-HX-xx-ZA3/4.

5.12.3 Technical data

The digital inputs comply with the IEC61131-2 TYPE 2 industry standard.

Voltage range	+22 ... 26 VDC
Switching level low/high	<5 VDC / >11 VDC
Current consumption at 24 V	typ. 8 mA
Cable cross section	max. 1,5 mm ²

5.12.3.1 Connection

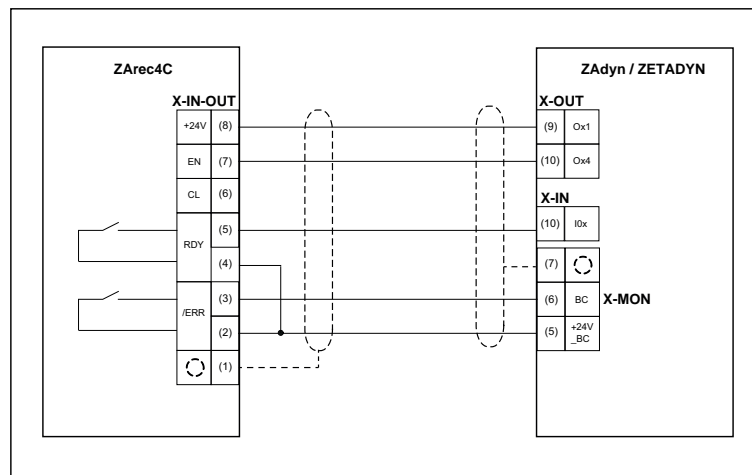

Connecting digital inputs and outputs to frequency inverter of type ZAdyn/ZETADYN

ZAdyn/ZETADYN:

Digital inputs X-IN: IOx configured to function ZR_RDY

Digital outputs X-OUT: Ox1/Ox4 configured to function ZR_EN

5.13 Digital outputs (X-IN-OUT)

The connection terminal X-IN-OUT is equipped with 2 digital outputs as zero potential relay contacts with normally open function.

5.13.1 Function of the outputs

Output	Function	Explanation
RDY	"ready" message	Contact is closed if no error is present in the ZArec4C. Contact opens in case of error or parameter input. When the RDY output is open, the EN input may not be activated.
/ERR	"error" message	Contact is closed if no error is present in the ZArec4C. Contact opens when errors occur which require the system to be switched off. It must be ensured that the system is locked when switching off the /ERR output. Errors must be fixed by qualified personnel.

5.13.2 Lead

- Shielded cables must be used. The shieldings must be connected to the shield connection of the X-IN-OUT terminal.
- It is recommended to use the pre-assembled connection cable LS-ZArec4C-xx-HX-xx-ZA3/4.

5.13.3 Technical data

Short-circuit-proof	no*
Min. switching capacity	5 mA / 12 VDC
Max. switching capacity	2 A / 250 VAC
Cable cross section	max. 1,5 mm ²



Caution

High interrupting voltages

Destruction of relay contacts

▷ Inductances must be provided with an external protective circuit (free-running diode, RC-member).

5.13.4 Connection

For connecting digital outputs see Chapter "Digital inputs (X-IN-OUT) / connection".

5.14 Input X-EN_MC (only in the case of ZArec4C 026/039)

If the bridge at the input X-EN_MC is removed, the activation of the internal mains relay is interrupted.

5.15 Signal timing

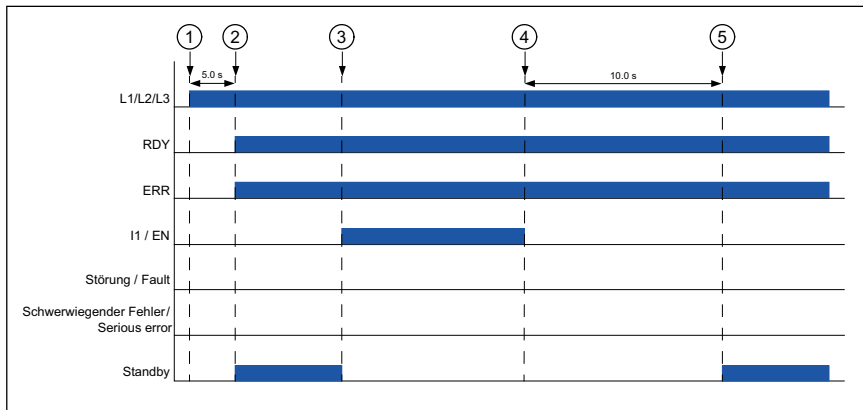

Normal travel

- 1 Line voltage
- 2 Outputs and standby mode active
- 3 Travel start / enable ZArec4C
- 4 End of travel
- 5 Activation of stand-by mode

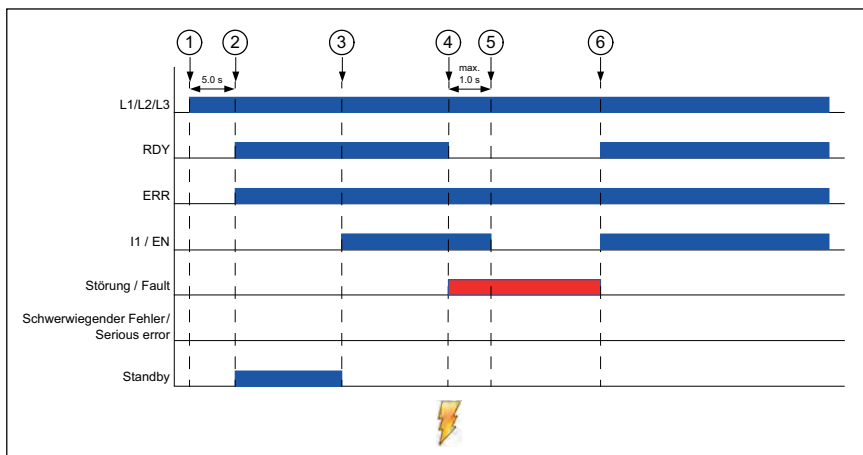

Failure

- 1 Line voltage
- 2 Outputs and standby mode active
- 3 Travel start / enable ZArec4C
- 4 Fault
- 5 Switch off enable ZArec4C
- 6 No fault is present / new travel command possible

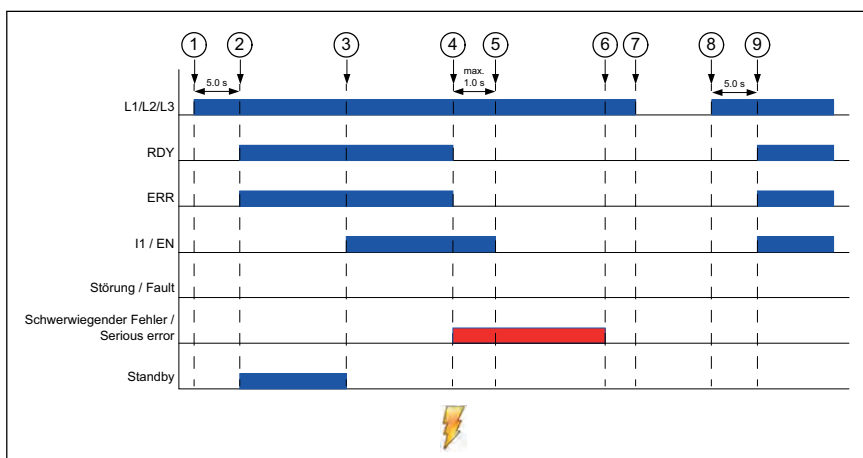

Serious error

- 1 Line voltage
- 2 Outputs and standby mode active
- 3 Travel start / enable ZArec4C
- 4 Error

- 5 Switch off enable ZArec4C
- 6 Error is no more present
- 7 Acknowledge by switching off mains voltage
- 8 Line voltage
- 9 new travel command possible

5.16 Circuit suggestion, ZArec4C and ZAdyn4C

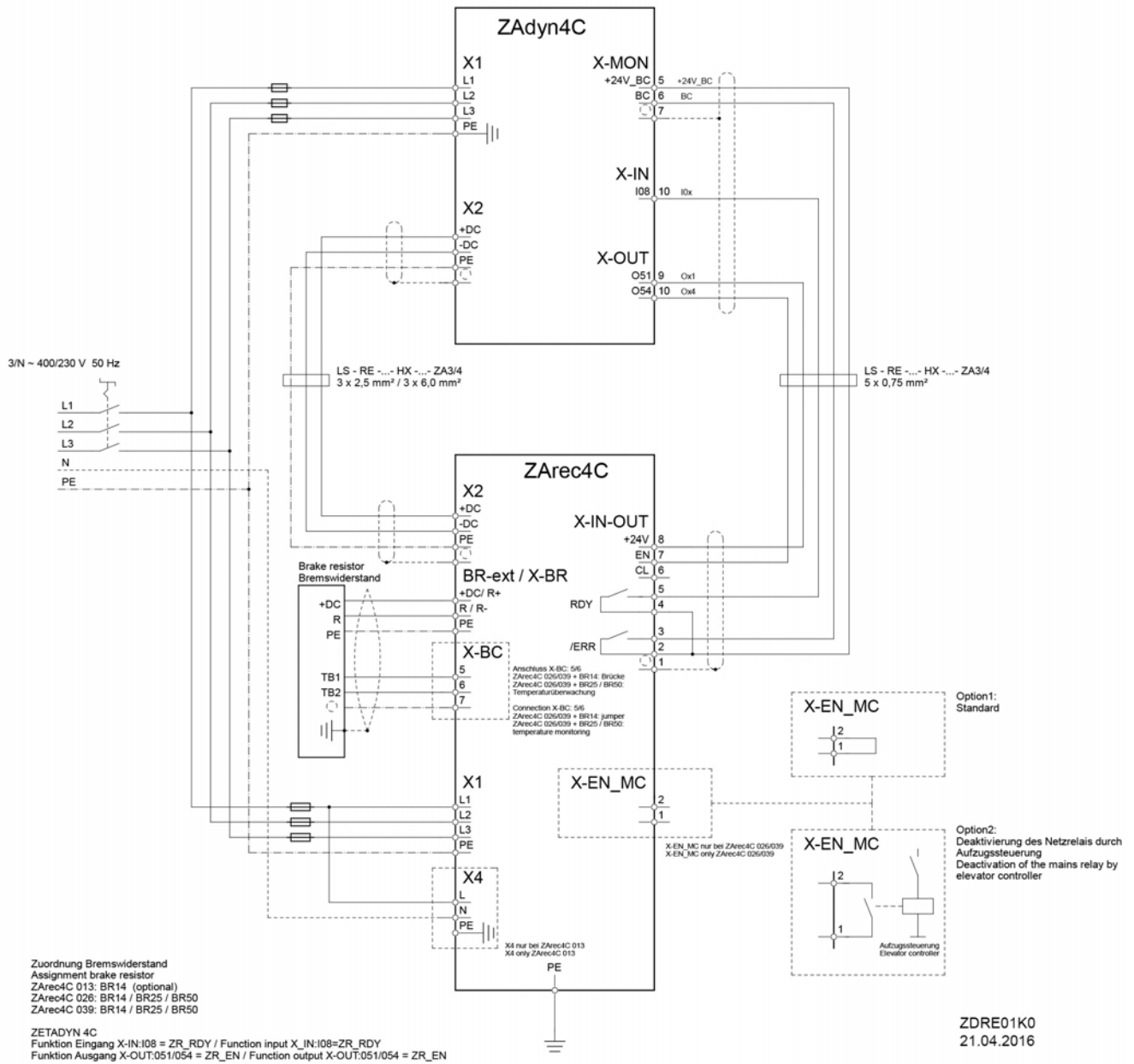

5.17 Circuit suggestion, ZArec4C and ZA dyn4C - UPS evacuation

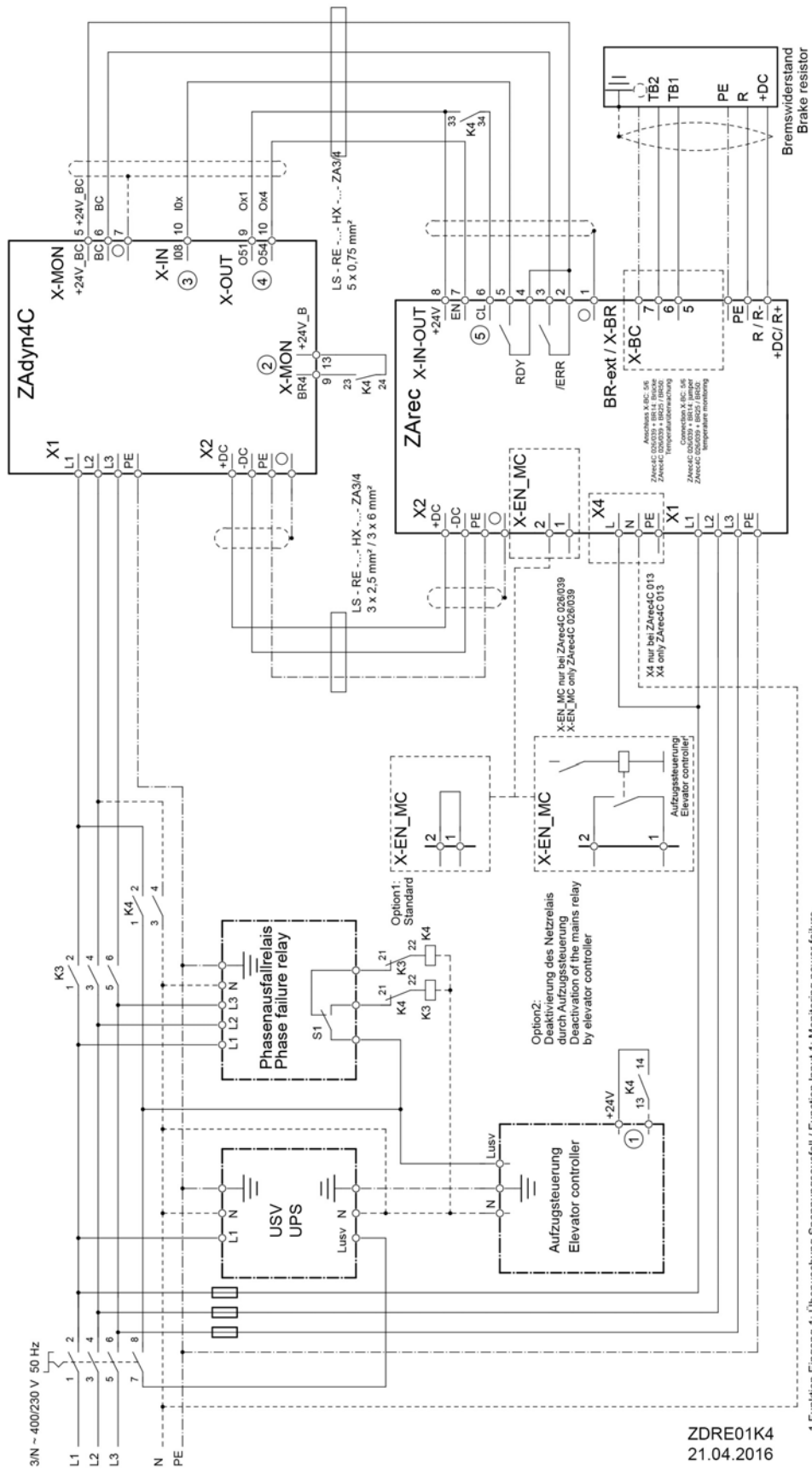

5.18 Circuit suggestion, ZArec4C and ZAdyn4C - 3~ evacuation

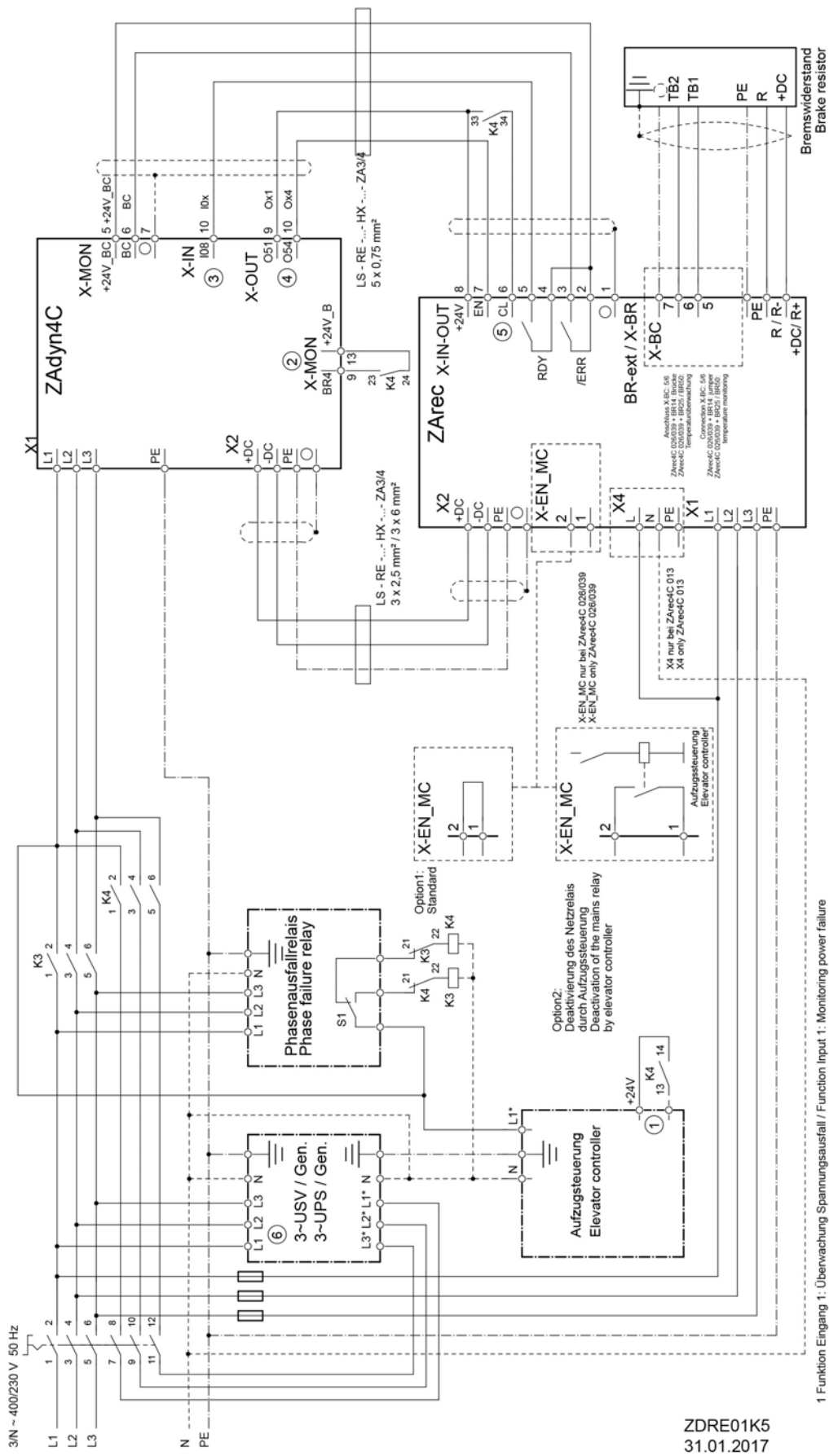

ZDRE01K5
 31.01.2017

- 1 Funktion Eingang 1: Überwachung Spannungsausfall / Function Input 1: Monitoring power failure
- 2 Funktion Eingang X-MON/BR4 = PARA2 / Function input X_MON/BR4=PARA2
- 3 Funktion Eingang X-IN/IO8 = ZR_RDY / Function input X_IN/IO8=ZR_RDY
- 4 Funktion Ausgang X-OUT/051/054 = ZR_EN / Function output X-OUT/051/054 = ZR_EN
- 5 Funktion Eingang X-IN-OUT/CL = LockRec/ Function input X-IN-OUT/CL = LockRec
- 6 Anschluss L1, L2, L3 bei Generator nicht erforderlich / Connection L1, L2, L3 not required for generator

5.19 Circuit suggestion ZArec4C, ZAdyn4C and EVAC 3C

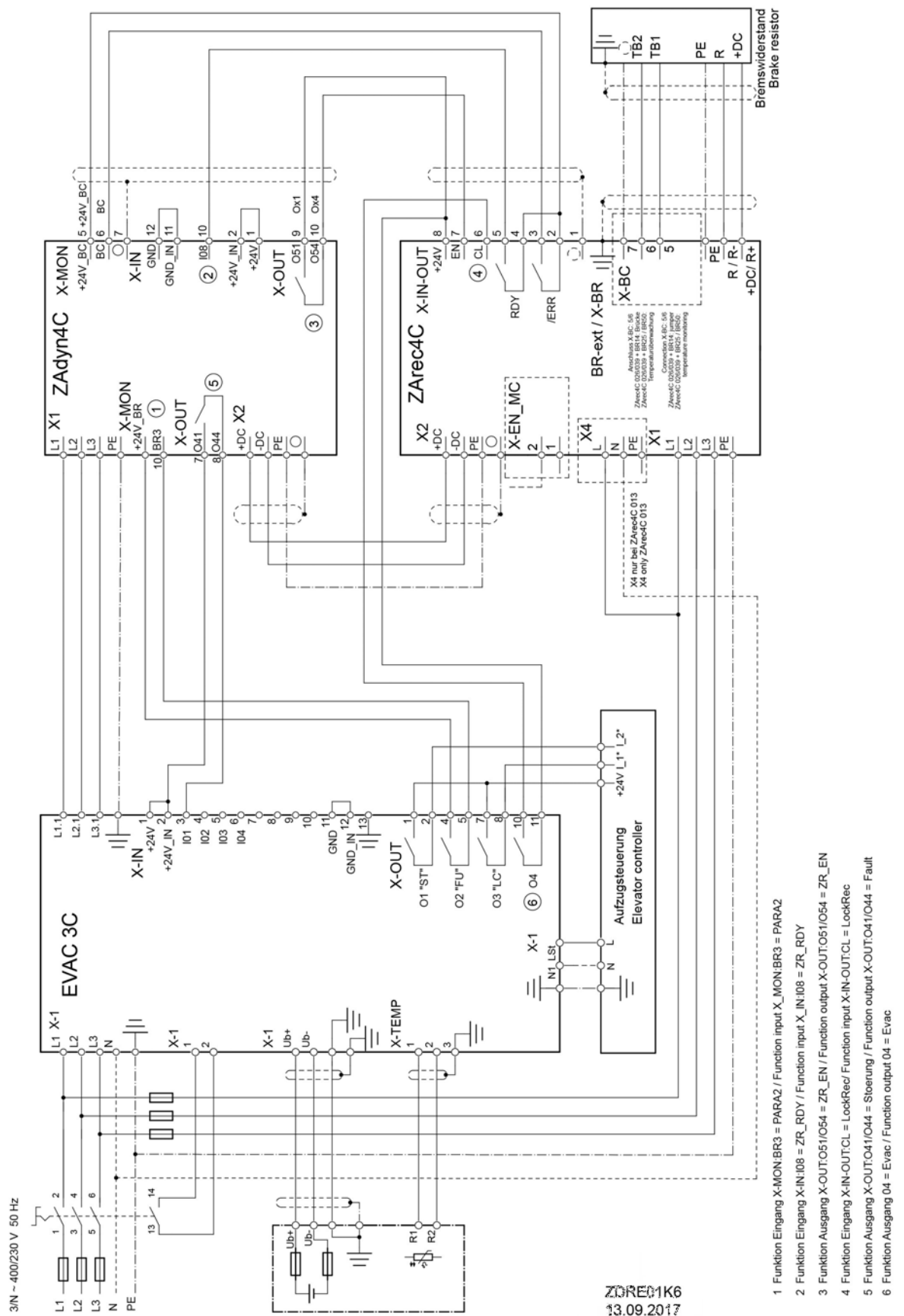

6 Accessories

6.1 ZApad control terminal

The ZApad is an operating module independent of the ZArec4C. It is used for special functions such as reading out errors and changing parameters.

When using a longer network cable, remote control of the ZArec4C is feasible.

6.1.1 Dimensions

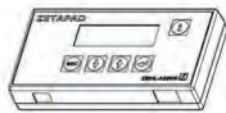
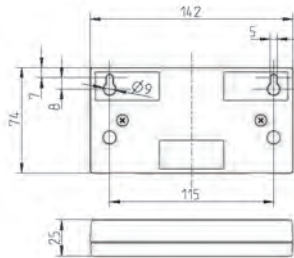

Dimensions ZApad

6.1.2 Connection

The connection has to be effected on the RJ45-female plug of the operating terminal and the ZArec4C (X-PAD).

Connection cable

CAT5 network cable, 8-core
both sides RJ-45 plug, 8-pole
maximum line length: 50 m
line cross-section \geq AWG26



Connecting ZApad to ZArec4C 013

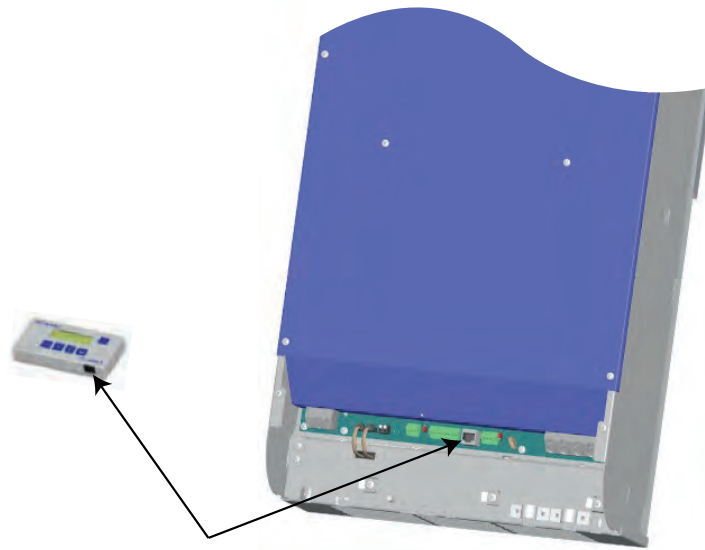

Connecting ZApad to ZArec4C 026/039

7 Operation and parameterising

7.1 Possibilities for operation and configuration

The following operations can be performed on the ZArec4C with the aid of the various operating facilities:

- The parameters needed for commissioning can be set
- Simple measurement and control functions can be carried out
- Service conditions can be recorded

7.1.1 ZApad control terminal

See the "Additional Devices/Operating Terminal ZApad" chapter for information about the ZApad operating terminal.

7.1.2 Remote control via ZAmon software

The ZAmon-software can be used to operate the ZArec4C with a PC / Notebook.

7.2 Menu navigation



Information

The menu navigation is designed identically for ZApad and ZAmon operating facilities!







Information

Modifying parameters is only possible when the machine is in standstill!



ZApad user interface

7.2.1 Control key functions

	<ul style="list-style-type: none"> • back to menu selection • Back to parameter selection • Negation of yes-no queries • Cancel
	<ul style="list-style-type: none"> • Confirming menu selection • Confirming parameter values • Confirming parameter values • Affirmation of yes-no queries
	<ul style="list-style-type: none"> • Menu selection • Parameter selection • Increasing parameter values
	<ul style="list-style-type: none"> • Menu selection • Parameter selection • Reducing parameter values
	<ul style="list-style-type: none"> • Show / exit INFO menu • Display of current operational states

7.2.2 Menu and parameter navigation

Main page	<pre>ZArec4C 013 ZIEHL-ABEGGSE SN: 09229587/0002 Phone: +49 794016308</pre>	- Press any key
Menu section	<pre>LCD & Password ->Basics Controller Filter</pre>	- Select required menu Confirm menu selection
Parameter section	<pre>Base Setup ->U_GRID 0 V U_DC_RF 0 V</pre>	Parameter selection - Confirming parameter values
Changing parameter	<pre>Base Setup ↳ U_GRID 0V ↳ 400 Rated mains voltage</pre>	- Enter / select parameter value. - Confirm value

8 Start-up

8.1 Safety instructions

CAUTION!

Warning!

Incorrectly wired connections can destroy the electrical/electronic components. Electrostatic discharges can be hazardous to the electronic components and lead to errors in the software.

You must comply with the following points to prevent damage to the ZArec4C or life-threatening injuries when commissioning the ZArec4C:

- The start-up of the ZArec4C may only be carried out by qualified persons under consideration of the safety instructions.
- Before starting work, make sure all tools and external parts have been removed from the ZArec4C.
- Activate all safeguards and the emergency-off switches before commissioning.
- Make sure no unauthorized persons are in the working area of the ZArec4C and that no other persons can be endangered when the ZArec4C is started up.
- inspect the electrical connections before the first start
- Pay special attention to the protective measures (e.g. grounding, ...) for the electrostatically endangered components.
- Also read the chapter "General Safety Instructions".

Requirements for error-free commissioning:

- Mains line is connected
- Control voltage connected
- if necessary, external brake resistance connected
- Control cables connected
- DC cable connected

8.2 Switching on the ZArec4C

Only applying the mains voltage the ZArec4C switches on after a self-test. The following display appears:

```
ZArec4C 013
ZIEHL-ABEGGSE
SN: 09229587/0002
Phone: +49 794016308
```

8.3 Configuring the ZArec4C

When starting up the ZArec4C in combination with ZAdyn it is not necessary to enter parameters on the ZArec4C.

8.4 Parameterisation of the ZAdyn

In order to be able to use the ZArec4C in combination with ZAdyn, the following parameters must be set in the menu of the ZAdyn:

Select "ZArec" in the parameter **Encoder & BC / BC_TYPE**.

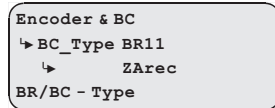

Information

This setting should also be made if an additional external brake resistor is used, or if a 2nd parameter set is used.

In the **Control** menu, parameterise the digital input of the ZAdyn (preferably I08) connected to the digital RDY output to "ZR_RDY".

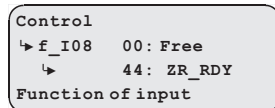

In the **Control** menu parameterise the digital output of the ZAdyn (preferably f_5) connected to the digital input EN to "ZR_EN".

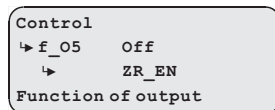

9 Parameter list

The individual parameters are subdivided into various menus based on their functions.



Information

Not all the described parameters are freely accessible and visible. The display depends on the selected functions and settings in the ZArec4C.

9.1 LCD & Password menu

Selecting the desired operating language

Parameter	Designation	Value range	Factory setting
LCD	Select the desired operating language.	Deutsch English	Deutsch

9.2 Basics

Parameter	Designation	Value range	Factory setting
U_GRID	Entering the mains rated voltage	380...400 V	400 V
F_GRID	Entering the mains rated frequency	50 Hz 60 Hz (on request)	50 Hz
U_DC_RF	Input of the nominal voltage for return feed operation	630...730 V	670 V
T_STDBY	Input of time since last travel until the ZArec4C switches to standby mode	0...65535 s	240 s

Parameter	Designation	Value range	Factory setting
BR_TYP	Input of the used brake resistance Off: no brake resistance used BR11: Brake resistor type BR11-A BR11+BR14: BR11 and BR14 BR14: Brake resistor type BR14 BR17-1: Brake resistor type BR17 BR25-1: Brake resistor type BR25 BR50: Brake resistor type BR50	Off BR11 BR11+BR14 BR14 BR17 BR25 BR50	ZArec4C 013: BR11 ZArec4C 026: BR25 ZArec4C 039: BR50
f_CL	Input function of the input CL ClrError: Reset the lock LockRec: Locking of return feed function. This function is used in conjunction with a three-phase UPS or if there is a failure of individual phases. The energy is completely discharged via the brake resistor.	ClrError LockRec	LockRec

9.3 Monitoring menu

Configuring the monitoring functions

Parameter	Designation	Value range	Factory setting
MOD_ERR	Behaviour of the ZArec4C in case of faults Block function: In the event that successive errors are reported but an error-free run is performed, you have the option of blocking the ZArec4C. The error output (/ERR) stays open. The counter is set to 0 when an error-free run is performed. Never: no locking function Lock n.3: Locking function after 3 errors. The error output (/ERR) drops out after the 2nd error. Lock n.2: Locking function after 2 errors. The error output (/ERR) drops out after the 2nd error. Lock n.1: Locking function after 1 error. The error output (/ERR) drops out after the 1st error. The errors that lead to locking are marked accordingly in the error list.	Never Lock n.3 Lock n.2: Lock n.1	Lock n.3
UDC_MIN	Input of the minimum intermediate circuit voltage If the value drops below this minimum value, an error message is output.	100...500 V	450
MASK1	Error mask 1...3		0
MASK2	Suppression of up to three error messages through configuring the corresponding error number in an error mask	0...3999	0
MASK3			0

9.4 Controller menu

Parameter	Designation	Value range	Factory setting
U_DC_SR	Speed with which the voltage of the intermediate circuit is increased	100...1,500 V/s	1,000 V/s

9.5 Filter menu

Parameter	Designation	Value range	Factory setting
LP_I_IN	Frequency of the low pass for the input current	100...4000 Hz	100 Hz

9.6 Statistic menu

All statistical data can be called up in the **Statistics** menu. The data will be retained even after the ZArec4C has been switched off. Reading out the error list and deleting the error memory are described in the chapter "Error diagnosis".

Parameter	Designation	Value range	Factory setting
ST_LST	Error list	Cannot be set	-
ST_H	Operating hours	Cannot be set	-
ST_DRV	Number of trips	Cannot be set	-
ST_RES	Number of mains interruptions	Cannot be set	-
ST_GE	Number of mains disturbances	Cannot be set	-
ST_SD	Number of mains disturbances	Cannot be set	-
ST_CLR	Delete error memory Deletion of ST_LST and ST_RES	On Off	Off
RESET	99: Device reset, parameters are deleted and set to factory settings. Software version number (e.g.: Version 4.01 -> "401"): Reset parameters ST_H, ST_DRV, ST_RES as well as the energy meter and the system time. Recorder settings are overwritten by factory settings.	0...65535	0

9.7 Memory Card menu

Contains the parameters for the various functions in association with a memory card.

Parameter	Designation	Value range	Factory setting
SAV_ALL	Saves error lists (.FLT) and printer lists (.PRT) to memory card with serial number allocation. The lists are saved in the ZR4/DEVICE/SerialNumber/LST folder. Off: no function ON: Error list and printer list are saved on memory card. The parameter jumps back to "Off" after saving.	On Off	Off
SAV_PAR	Save parameters to memory card (copy parameters in the case of identical systems): • Parameter (.PA3) in the folder /ZR4/DEVICE/FORCE Here, there is no serial number allocation. The data will be overwritten during each saving Off: no function ON: Parameters are saved on memory card. The parameter jumps back to "Off" after saving.	On Off	Off
LOD_PAR	Load parameters from memory card to the ZArec4C (copy parameters in the case of identical systems) Input 27: Parameters (.PA3) are loaded from the /ZR4/DEVICE/-FORCE folder into the ZArec4C. The parameter jumps back to "Off" after loading.	0...27	0

9.8 MMC-Recorder menu

You have the option of performing measurements on the ZArec4C using a memory card without the need for a notebook. The measurement is configured in the **MMC recorder** menu.

Parameter	Designation	Value range	Factory setting
REC_MOD	Recorder settings Off: Recorder is switched off On: Recorder is active, the data are saved on the memory card Stop&Shot: Manual stopping and saving of a measurement which was started with MOD=ON". After saving the data on the memory card, REC_MOD will set to "Off". ZAmon: Mode for using ZAmon software	Off On Stop&Shot ZAmon	ZAmon

9.9 Power section menu

Configuration of the power component.

Parameter	Designation	Value range	Factory setting
f_PWM_H	Cycle frequency with which the fed back current is modulated	nicht einstellbar	16.0
U_BC_OF	BC engagement voltage offset	5...15 V	5 V
ADJ_UDC	Correction factor to synchronise the input voltages of the ZAdyn and the ZArec4C intermediate circuit	0.950...1.050	1,0
FAN	Setting of the speed of the internal fans AUTO: Speed is adapted to the temperature of the power unit ON 100%...ON 10%: Setting of the speed in per cent of the maximum speed OFF: internal fans deactivated	AUTO On 100%...On 10% Off	AUTO
FAN_T	Temperature of the power unit at which the internal fans switch on The parameter only has an effect in the case of the ZArec4C 013.	28...45 °C	33

9.10 CAN menu

Activation of the ZArec4C by CANopenLift is not yet supported at the moment.

9.11 ZA-Intern menu

The **ZA-Internal** menu contains hidden parameters which only become visible after entering a password.

Parameter	Designation	Value range	Factory setting
PW_S9	Password to show additional parameters	0...65535	0

9.12 INFO menu

<pre>Serial-No ----- 01 ZAreC4C 013 SN: 06128298/0001 4.01 27054</pre>	<p>Page 01: Serial-No. Line 2: Indication of the recuperation unit type and size: Line 3: Serial number/type consecutively numbered Line 4: Software version</p>
<pre>ENERGY ----- 02 W_R: 0.00 kWh</pre>	<p>Page 02: ENERGY total amount of fed back energy in kilowatt hours</p>
<pre>Info POWER ----- 03 P_GRID: + 0.0kW P_BC: + 0.0kW Duty_BC: 0%</pre>	<p>Page 03: Info POWER Line 2: power currently fed into the mains in kilowatts Line 3: power currently output via the brake resistance in kilowatts Line 4: Modulation of the brake resistance in per cent</p>
<pre>Info DUTY 10 min -- 04 ED_REC_ACTIVE: 0% ED_REC_PWM_ON: 0% LOAD_BR(120s): 0%</pre>	<p>Page 04: Info DUTY 10 Min On time during the last 10 minutes Line 2: On time of the return feed mode Line 3: On time of the PWM unit Line 4: Brake resistor utilisation during the last 120 seconds</p>
<pre>READ_INFEB ----- 05 WAIT_START_BC no error INFEB_ERROR</pre>	<p>Page 05: Line 1: Return feed status Line 2: BR activation status Line 3: Error text Line 4: Message text</p>
<pre>Info STATE ----- 06 STAT_RS: 70 Msg: 0 STAT_BC:110 Err: 0 Udc: 547V IN:545V</pre>	<p>Page 06: Line 2: STAT_RS: Return feed status Msg: Message number Line 3: STAT_BC: BR activation status Err: Error number Line 4: Udc: ZAreC4C intermediate circuit voltage IN: Voltage present at the connection terminal to which the ZAdyn intermediate circuit is connected</p>

10 Error diagnosis

10.1 General

If the ZArec4C detects an error, the RDY output drops out at the end of travel. In case of errors which demand switching off, the /ERR output drops out immediately.

The error that occurs is displayed with error text and error number. A LED, the error memory and the error list are available for further error diagnosis.

10.2 Acknowledgement

To acknowledge an error, you have to switch the ZArec4C off and back on.

10.3 LED

There is a LED on the ZArec4C for diagnosis.



1 Position of LED ZArec4C 013

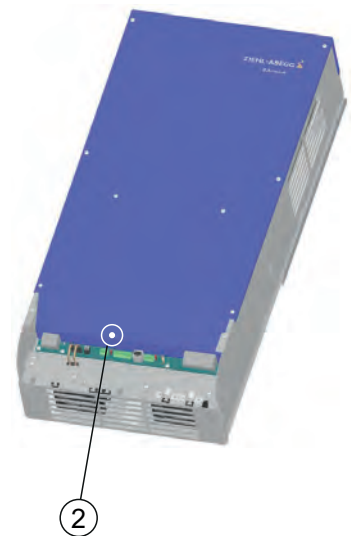

2 Position of LED ZArec4C 026/039

Meaning of the LED

LED colour	LED status	Meaning
green	flashing	Normal operation
red	flashing	Display error no. by blink code: Number of blinks = Error no. - 100 Example: 8 x red blink -> Error no. 108 then 1 x white blink as a separating character
yellow	flashing	Display message no. by blink code: Number of blinks = message no. Example: 6 x yellow blink -> Message no. 6 then 1 x white blink as a separating character

10.4 Readout the error memory

Errors are saved in the error list. The error list is in the Statistics/ST_LST menu. Up to 64 error messages can be managed. Once the number of 64 messages has been reached, the oldest entry in each case is deleted for each new error message which arises. When the error list is opened, the last error which occurred is displayed with the following information:

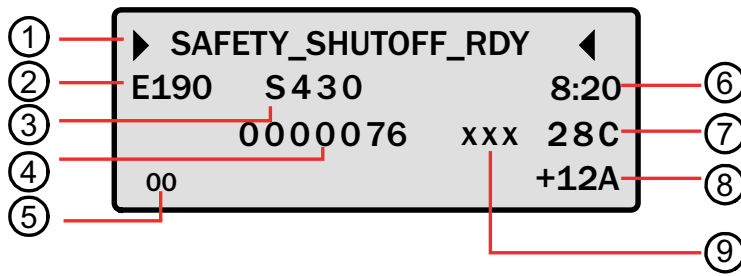

- 1 Error description
- 2 Error no.
- 3 Operation condition (S=status)
- 4 Travel number
- 5 Consecutive error number
- 6 Operating hours
- 7 Temperture power stage
- 8 fed back current
- 9 Additional information

Please refer to the "Error diagnosis" chapter for a description of the error number and the operating condition.

The following information is displayed when the error list is opened and the **i** key is pressed additionally:

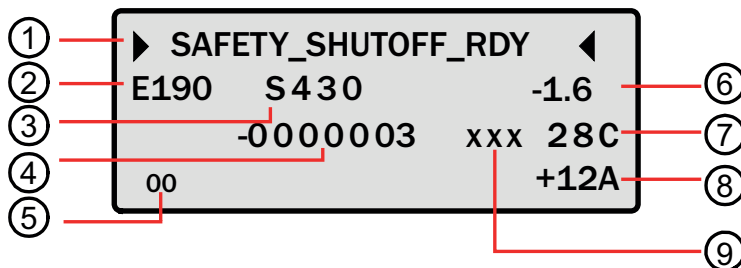

- 1 Error description
- 2 Error no.
- 3 Operation condition (S=status)
- 4 Indication how many trips ago the error occurred
- 5 Consecutive error number
- 6 Time how long ago the error occurred
- 7 Temperture power stage
- 8 fed back current
- 9 Additional information

Scroll through fault list:

the fault list can be scrolled through using the two arrow keys.



Scroll up (reduce fault serial number)



Scroll down (increase fault serial number)

Determine time of fault



After pressing the i key, the difference from the current number of travels and operating time is displayed

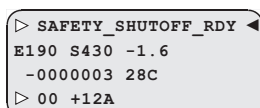

10.5 Delete error memory

The fault memory is wiped by means of an entry in the **Statistic / ST_CLR=ON**.
 The following parameters are reset:

- ST_LST (Error list)
- ST_RES (Number of interruptions in the mains supply)

10.6 Error list

All error messages are stored in the **Statistic / ST_LST** menu (see "Error diagnosis / error memory" chapter)

10.6.1 Masc-Funktion

Individual monitoring functions can be deactivated by an entry in the error mask (see chapter "Parameter List/Monitorings Menu"). The appropriate error number must be entered in one of the error masks 1-3 for this.

The maskable errors are marked in the error list with a **point** in the column **M**.

Warning!

CAUTION!

The mask function may only be used for troubleshooting and error diagnostics. The corresponding error cause must be eliminated to ensure continuous service of the ZArec4C!

Sequential errors can occur if errors are masked.

The masking deactivates important monitoring functions. This may result in dangerous operating states or damage to the ZArec4C.

10.6.2 Block function

Blocks the ZArec4C and the frequency inverter if certain errors occur several times in succession. The errors must occur in directly consecutive travel tests. The error counter is set to 0 when performing a trouble-free travel.

Errors that lead to locking of the ZArec4C lead to a travel abort.

The locking functions can be parameterised in the **Monitorings / MOD_ERR** menu.

Errors which lead to locking of the ZArec4C are identified by a **dot** in the **S** column.

If the ZArec4C is locked, no operation is possible with the ZApad. The LED switches through RED-GREEN-BLUE.

Error no.	Error text	Error cause	M	S
0	no error	error-free state		
101	MAIN_CON_DONT_CLOSE	Error: Mains contactor does not close Remedy: Check control voltage at X4		•
102	MAIN_CON_DONT_OPEN	Error: Mains contactor does not open		•
103	MAIN_CON_INTERRUPT	Error: Mains contactor opened again after closing Remedy: Check control voltage at X4		•
104	CA_TRIP_ZONE_UVW	Error: Overcurrent phase U, V or W Cause: Phase failure or phase shift on the mains		•
105	OVERVOLTAGE	Error: Overvoltage		•
106	PLL_FAIL	Error: No synchronisation with the mains		•
107	BAD_GRID_1	Error: Mains fault type 1		•
108	BAD_GRID_2	Error: Mains fault type 2 There is a phase error for more than 20 ms!		•
109	CA_XINT1_ERR_I_UVW	Error: Overcurrent phase U, V or W		•
110	CA_XINT2_ERR_I_DC	Error: Overcurrent DC input current 30-s-restart pause.		•
111	CA_XINT3_ERR_U-CE_UVW	Error: U_CE monitoring Phase U, V or W. 30-s-restart pause.		•

Error no.	Error text	Error cause	M	S
112	CA_XINT4_ERR_U-CE_BC	Error: U_CE monitoring brake resistance		•
113	SY_FLT_UVW	Error: Error IGBT driver Phase U, V or W		•
114	SY_FLT_BC	Error: Error in the IGBT driver brake resistance		•
115	VOLTAGE_BOOST_FAIL	Error: The DC nominal voltage U_DC_RF is not reached.		•
117	OVERVOLTAGE2	Error: Overvoltage in detected phase failure		•
118	CA_TRIP_ZONE_UVW2	Error: Overcurrent Phase U, V or W in detected phase failure		•
119	CA_XINT1_ERR_I_UVW2	Error: Overcurrent Phase U, V or W in detected phase failure		•
120	CA_TRIP_ZONE_BC	Error: Overcurrent brake resistance		•
121	CA_TRIP_ZONE_BC	Error: Overcurrent brake resistance		•
122	INPUT_SC_OPEN	Error: Thermostat switch has opened Remedy: Let device cool down, wait until fans switch off and then reset.		•
125	EVAC_DC_ABORT	Error: An input voltage is detected in EVAC mode with DC voltage		•
130	WIRING_FAULT_A	Error: internal wiring error A	•	•
131	WIRING_FAULT_B	Error: internal wiring error B	•	•
140	SET_PARA_TO_DEFAULT	Error: The error message is displayed if parameter values saved in the EEPROM are outside the permissible range (e.g. after software update). The appropriate parameters are set automatically with the default value. The number of the altered parameter is saved in the error message as additional information. If several parameters were altered, the number of the parameter with the highest number is saved.		•
150-159	GRID_*	Error: Various mains disturbances occurring over a longer period.		•
171	OTA_POWERSTAGE	Error: overtemperature power stage RDY switches off and ZAdyn waits.		•
172	OTA_ENVIRONMENT	Error: Overtemperature environment RDY switches off and ZAdyn waits.		•
173	OTA_CHOKE	Error: On time choke RDY switches off and ZAdyn waits.		•
174	OTA_TRANSFORMER	Error: On time transformer RDY switches off and ZAdyn waits.		•
175	OTA_BC	Error: On time brake resistance RDY switches off and ZAdyn waits.		•
176	OTA_LOAD_BR	Error: Brake resistor load capacity exceeded. RDY switches off and ZAdyn waits.		•
190	SAFETY_SHUTOFF_RDY	Error: The Enable (EN) input remains active although the Ready (RDY) output was switched off. Check ZAdyn setting.		•
191	SAFETY_SHUTOFF_BC	Error: If the input voltage is below the engagement voltage of the BC and an input current > 3 A is flowing, it switches off after 2 s.		•
192	SAFETY_SHUTOFF_TEST	Error: A value not equal to 0 must be set for the "TEST" parameter Remedy: Change parameter to 0		•
193	SAFETY_SHUTOFF_SC	Error: Overtemperature thermostat switch Remedy: Let device cool down, wait until fans switch off and then reset.		•
194	SAFETY_SHUTDOWN	Error: ZAreC4C switched to Shutdown state		•

10.7 Message list

Messages are notes. They do not lead to locking of the ZArc4C.

Messages are displayed in the **Info menu/page 05** in line 4 (see chapter "Parameter List / INFO Menu").

Message no.	Message text	Designation
0	no msg	no message
2	BC_ALARM	The BC is not ready 1 s after enable.
3	PARA_ERROR	Configuration error Remedy: undo last change or do reset 99
4	PO_INP_SC_OPEN	Thermostat switch of the internal BR and the choke is open Remedy: Let device cool down, connects automatically when contact closes
5	MAIN_CON_NOT_OPEN	Mains contactor is not open Remedy: Check internal wiring, auxiliary contact does not work.
6	NO_ROTARY_FIELD	No rotary field detected Remedy: Check mains voltage at the input
7	BAD_GRID_1	Mains fault type 1
8	BAD_GRID_2	Mains fault type 2
9	UNDERVOLTAGE	Intermediate circuit voltage < Parameter UDC_MIN
10	WRONG_ROTARY_FIELD	no right hand rotary field Remedy: Change phase sequence at X1
11	I_SENS_U_FAULTY	A current is measured in the phase U with open mains contactor
12	I_SENS_V_FAULTY	A current is measured in phase V with open mains contactor.
13	I_SENS_W_FAULTY	A current is measured in phase W with open mains contactor.
14	PLL_TIMEOUT	Synchronisation with the mains failed
15	SW_FF_NOT_RESET	Software error
16	INP_SY_FLT_BC_ACT	Activation of BC failed
17	INP_SY_FLT_UV-W_ACT	Activation of power stage failed
18	UNSUPPORTED_MODE_1	The measured DC input voltage is > 410 V and there should be normal operation. However, no or faulty AC input voltage is measured. Remedy: Check power cable and fuse.
19	UNSUPPORTED_MODE_2	The measured DC input voltage is not in the permissible range between 360 and 410 V. None of the permissible modes provides such as DC voltage.
20	UNSUPPORTED_MODE_3	The measured DC input voltage is < 360 V and there should be EVAC operation. But an AC input voltage is still detected.
21	E2PROM_TIMEOUT	E ² PROM cannot be read out.
22	INFB_TIMEOUT	HW configuration cannot be read out.
23	INFB_ERROR	Read out configuration faulty
24	FAIL_REF_1V65	More than 5 % deviation in the reference sources
25	FAIL_REF_I_UVW	
26	FAIL_REF_I_DC_IN	
27	FAIL_SENSOR_I_U	One of the current sensors measures too high or too low value
28	FAIL_SENSOR_I_V	
29	FAIL_SENSOR_I_W	
31	FAIL_SENSOR_T_IGBT	Implausible value for IGBT temperature detected
32	FAIL_SENSOR_T_CAP	Implausible value for intermediate circuit temperature detected
33	FAIL_SENSOR_T_CHK-OK	Implausible value for choke temperature detected
34	FAIL_SENSOR_U_12	Implausible value for input voltage U12 detected
35	FAIL_SENSOR_U_23	Implausible value for input voltage U23 detected
36	FAIL_SENSOR_U_31	Implausible value for input voltage U31 detected
37	FAIL_SENSOR_U_DC	Implausible value for intermediate circuit voltage detected

Message no.	Message text	Designation
38	FAIL_SENSOR_U_DCIN	Implausible value for DC input voltage detected
39	FAIL_SENSOR_I_DCIN	Implausible value for input current detected
40	CALIB_ADC_FAILED	ADC calibration failed
41	PO_INP_SY_FLT_BC_ACTIVE	Error in the BC power stage during operation
42	PO_INP_SY_FLT_UVW_ACTIVE	Error in the UVW power stage during operation
43	PO_INP_MC_NOT_OPEN	Mains contactor is not open
44	PO_U_DC_LT_100V	DC input voltage < 100 V
45	PO_U_DC_GT_635V	DC input voltage > 635 V
46	PO_INP_HC_FLT_BC	Error in the BC power stage during operation
50	GRID_UNDERVOLTAGE	Line voltage too low
51	GRID_UNBALANCED	Mains voltage uneven
52	INP_HC_FLT_BC_ACT	Error in the BC power stage during connection
71	OTW_POWERSTAGE	Overtemperature warning power stage Remedy: Let device cool down
72	OTW_ENVIRONMENT	Overtemperature warning environment Remedy: Let device cool down
73	OTW_CHOKE	Overtemperature warning choke Remedy: Let device cool down
74	OTW_TRANSFORMER	Overtemperature warning transformer Remedy: Let device cool down
75	OTW_BC	Overtemperature warning brake resistance Remedy: Let device cool down
76	OTW_LOAD_BR	Advance warning overloading brake resistor Remedy: Let device cool down

11 Energy saving

The ZArec4C automatically switches to standby operation after the last run after an adjustable period of time. In standby operation, the mains contactor of ZArec4C is switched off.

The time until the ZArec4C changes to standby operation is entered in the **Basic settings/T_STDBY** parameter.

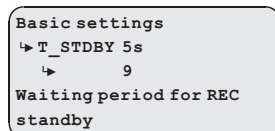

12 Special functions

12.1 Software update

- ▷ Connect the ZApad to the ZArec4C.
- ▷ Connect ZApad to the PC with a USB cable. For this purpose, connect the USB cable to the USB connection (1) of the ZApad.

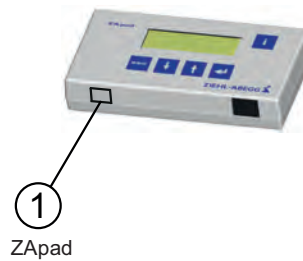

- ▷ Start ZAMon.

The ZApad and the ZArec4C must be shown in colour in the ZAMon program interface (2). This indicates that a connection has been made between the ZArec4C and the PC.

- ▷ Click on the "Flash" (3) button.

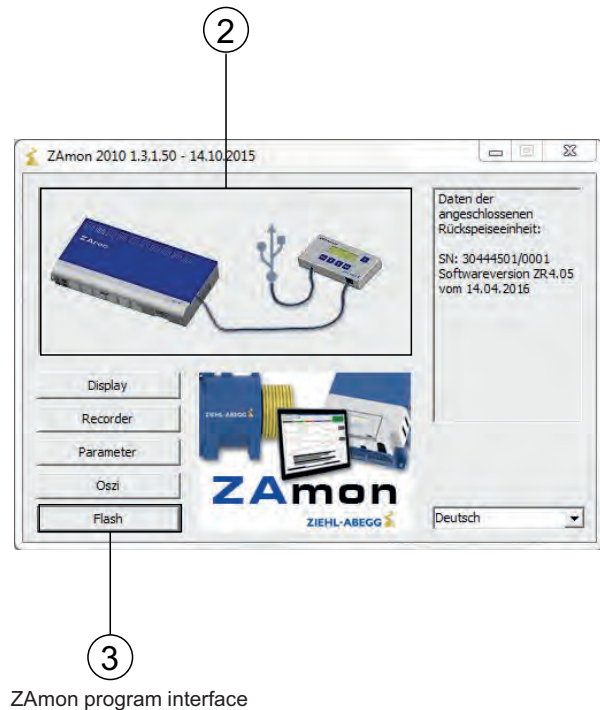

- ✓ The "Flash-Programmer" window opens (see figure ""Flash-Programmer" window").
- ▷ Select the "MOP/ZArec" (4) tab in the "Flash-Programmer" window.
- ▷ Click on the square button (5) and select the *.zre file which contains the new software version.
- ▷ Click on the "Flash" (6) button to start the software update.

An update may not be interrupted once it has started!

- ✓ When the software update is finished, in the "Status" field the message "Update finished, restart inverter!" appears.
- ▷ After the end of the software update, restart the ZArec4C.

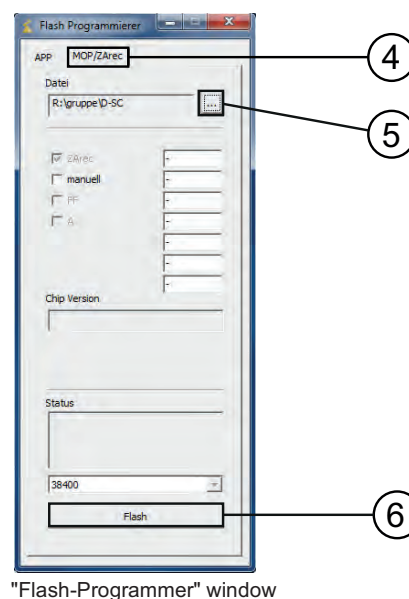

12.2 Parallel operation of two ZArec4C 013

It is possible to operate two ZArec4C in parallel.

12.2.1 Series circuit of inputs and outputs

The "EN" digital inputs and the "/ERR" digital outputs on the two ZArec4Cs must be connected in series.

12.2.2 Parameterisation of the ZAdyn

In the **Control** menu, a second digital output must be configured to ZR_EN in addition to the digital output f_O5.

12.2.3 Nominal voltage for the regeneration operation

The following values are to be entered for the regeneration operation nominal voltage:

	ZArec4C 1	ZArec4C 2
Rated voltage	720 V	710 V

The values are entered in the parameter **Basics / U_DC_RF**.

```
Basic settings
↳ U_DC_RF 630 V
  ↳      720
DC nominal voltage
```

12.2.4 Engagement voltage of the brake resistor

A higher brake resistor engagement voltage value must be entered than when using just one ZArec4C.

	ZArec4C 1	ZArec4C 2
BC engagement voltage offset	5 V	15 V

These values (offsets) are entered in the parameter **Power component / U_BC_OF**.

```
Power component
↳ U_BC_OF 5V
  ↳      5
BC engagement voltage offset
```

12.2.5 Correction factor

The measurement of the ZAdyn intermediate circuit voltage and the ZArec4C intermediate circuit input voltage may have different results due to tolerances. Therefore the correction factor must be calculated to synchronise the two values.

$$\text{Correction factor} = \frac{\text{displayed intermediate circuit voltage of the ZAdyn / ZETADYN}}{\text{displayed input voltage of the intermediate circuit of the ZArec4C}}$$

The intermediate circuit voltage of the ZAdyn is displayed in **Info menu page 07: Brake Chopper** of the ZAdyn in line 3

```
Brake Chopper ----- 07
Internal 1.4kHz BC •
U_DC: ----- 565V
Ampl: ----- 0%
```

The ZArec4C intermediate circuit input voltage is displayed in **Info menu page 06: Info STATE** of the ZArec4C in line 4, "IN:".

```
Info STATE ----- 06
STAT_RS: 70 Msg: 0
STAT_BC:110 Err: 0
Udc: 547V IN:545V
```

The factor is entered in the parameter **Power component / ADJ_UDC** for the two ZArec4Cs.

```
Power component
↳ ADJ_UDC 1,000
  ↳      1,000
Adj. = U_DC_dr. / U_DC_IN.
```

12.3 UPS evacuation

In UPS mode, the ZArec4C cannot feed any energy back into the supply network. The energy created during generator travel is completely discharged via the brake resistor. This enables travel to continue at a reduced speed for a limited period in case of mains failure.

- Single-phase UPS: See connection diagram in "Electrical installation/circuit suggestion, ZArec4C and ZAdyn4C - UPS evacuation"
- Three phase UPS or diesel generator: See connection diagram in Chapter 5.19

If all three phases of the line connection voltage at terminal X1 fail, the ZArec4C automatically shuts down the recovery function. If the recovery function is to be shut down regardless of the line connection voltage, this can be done using the digital input CL. To do this, the parameter **Default settings/f_CL** should be set to **LockRec**.

During commissioning, the correct function when switching between normal mode and evacuation mode must be checked.

For further information on UPS evacuation, refer to the "Emergency evacuation" and "Energy saving/-power feedback unit in conjunction with automatic emergency operation" chapters in the ZAdyn4C operating instructions.

13 Operating the ZArec4C with the frequency inverters from other manufacturers

The ZArec4C power feedback unit can also be operated in combination with frequency inverters from other manufacturers.

13.1 Requirements for the frequency inverter

- Mains voltage 400 V / 50 or 60 Hz (on request) +10/-15 %
- Permitted intermediate circuit voltage: Min. 680 VDC

13.2 ZArec4C control and evaluation

Activation of the digital input and evaluation of the digital outputs can be done both via the frequency inverter as well as the lift control.

13.2.1 EN enable digital input

The ZArec4C has the EN enable digital input.

Technical data

Voltage range	+22 ... 26 VDC
Switching level low/high	<5 VDC / >11 VDC
Current consumption at 24 VDC	typ. 8 mA
Clamping range	max. 1.5 mm ²

Function

- The ZArec4C automatically switches to standby mode after an adjustable period of time.
- To activate the return feed function, 24 VDC are switched to the EN digital input via a potential-free contact.
- The ZArec4C has an internal 24 VDC voltage supply for this purpose.
- EN may only be activated after the RDY output is active.
- EN must be deactivated within 1 s after switching off the RDY output.

13.2.2 Digital outputs

The ZArec4C has two digital outputs as potential-free relay contacts with N/O switch function.

Technical data

Short-circuit-proof	No
Min. switching capacity	5 mA / 12 VDC
Max. switching capacity	2 A / 250 VAC
Clamping range	max. 2.5 mm ²

13.2.2.1 RDY (O3) digital output - operational

- Information that the ZArec4C is operational
- Contact closes as soon as the ZArec4C is started up
- Contact opens in case of parameter input or a fault
- After remedying the cause of the fault, the contact closes again
- When the contact is open, it must be ensured that the EN input is not activated
- After switching off RDY, the EN input must be deactivated within 1 s

13.2.2.2 Digital output /ERR (O4) - errors requiring switching off

- Information that the internal temperature limits of the ZArec4C have been exceeded due to overloading and other errors, e.g. activation of the EN enable without the RDY output being active
- If /ERR decreases, the energy supply (via DC cable) must be interrupted by the frequency inverter.
- Qualified personnel must be on site for error analysis and remedy

13.2.3 Connecting digital inputs and outputs

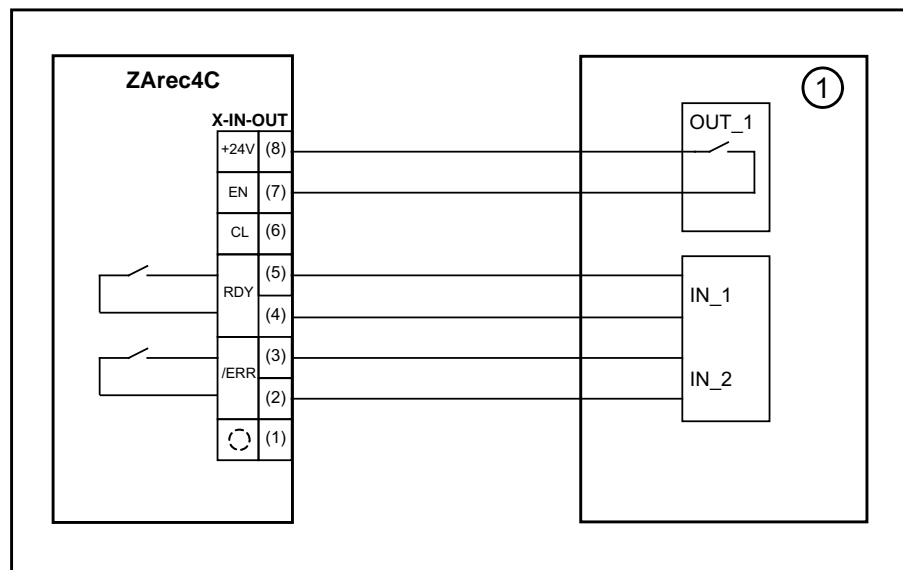

Connecting digital inputs and outputs

1 Frequency inverter/control

OUT_1 Output activation ZArec4C

IN_1 "ZArec4C ready" input

IN_2 "Error ZArec4C" input

13.3 Statuses of digital inputs and outputs

13.3.1 Normal travel

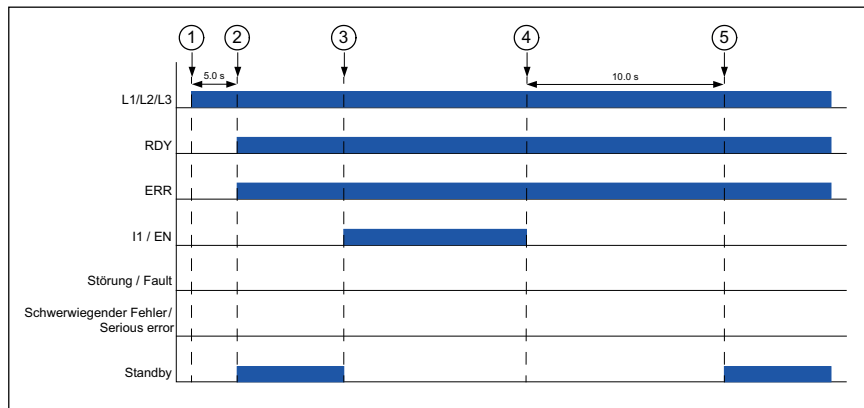

Normal travel

- 1 Line voltage
- 2 Outputs and standby mode active
- 3 Travel start / enable ZArec4C
- 4 End of travel
- 5 Activation of stand-by mode

13.3.2 Fault

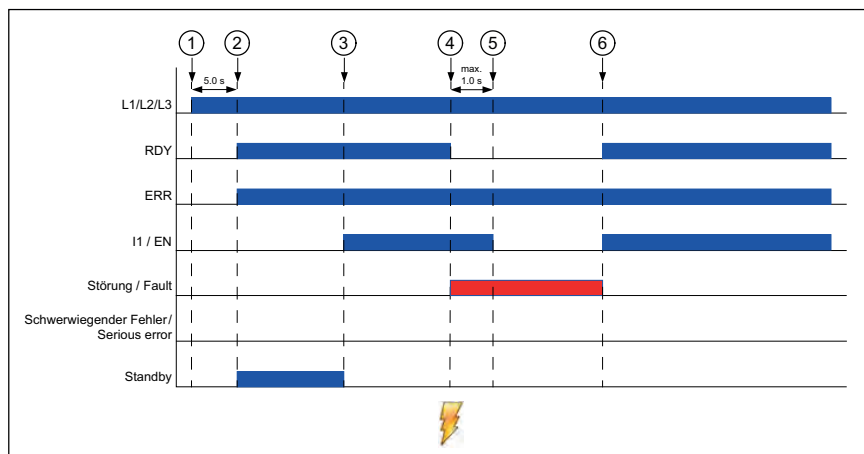

Failure

- 1 Line voltage
- 2 Outputs and standby mode active
- 3 Travel start / enable ZArec4C
- 4 Fault
- 5 Switch off enable ZArec4C
- 6 No fault is present / new travel command possible

13.3.3 Serious error

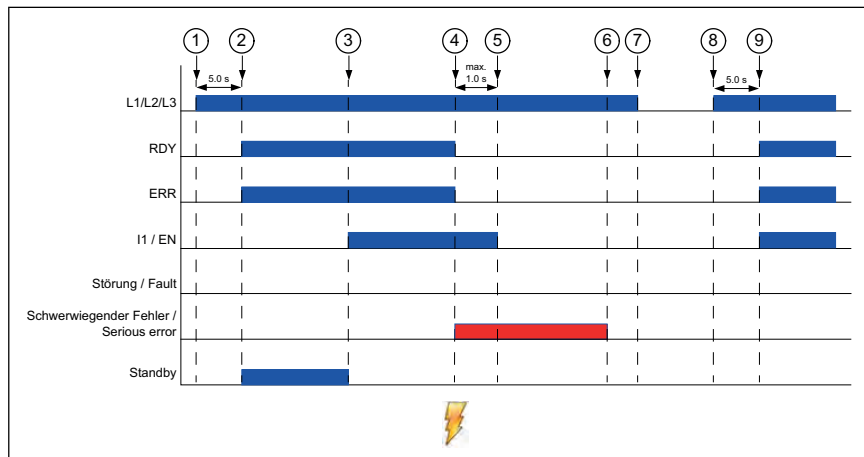

Serious error

- 1 Line voltage
- 2 Outputs and standby mode active
- 3 Travel start / enable ZArec4C
- 4 Error
- 5 Switch off enable ZArec4C
- 6 Error is no more present
- 7 Acknowledge by switching off mains voltage
- 8 Line voltage
- 9 new travel command possible

14 Enclosure

14.1 Technical data for ZArec4C

		ZArec4C 013	ZArec4C 026/039
Electrical data			
Mains connection voltage	[V]	3~ 400 +10 / -15 %	3~ 400 +10 / -15 %
Control voltage	[V]	230	
Mains frequency	[Hz]	50 (60 Hz auf Anfrage)	50 (60 Hz auf Anfrage)
Perm. mains asymmetry		≤ 3 % negative phase sequence	≤ 3 % negative phase sequence
Max. extractable power	[kW]	13	26/39
Max. regenerative power	[kW]	5	10/15
Max. regenerative power	[A]	7.2	14.4/21.7
Duty cycle at rated current and clock frequency 16 kHz	[%]	20	20
Rated current for 20 % switch-on duration and switching frequency 16 kHz fixed	[A]	7	14.4/21.7
Max. operating current	[A]	7	14.4/21.7
Power loss at rated current, switching frequency 16 kHz and 20% ED	[W]	500	989/1129
Power loss in standby	[W]	< 10,0	< 15
Switching frequency	[kHz]	16	16
Max. terminal cross-section X2/X-DC, BR-ext/X-BR	[mm ²]	6	16
Max. terminal cross-section X1, X4	[mm ²]	1.5	6
Internal diameter range screw cable glands brake resistance cable, DC cable, power cable	[mm]	9...17	
Internal diameter range screw cable gland control voltage cable	[mm]	4,5...10	
Fuse protection			2 x 25 A flink, 900 VDC, gPV, 10 x 38 mm
Ambient conditions			
The user must ensure that the specified ambient conditions are observed.			
Protection rating		IP20	
Ambient temperature for operation	[°C]	0 to 55, from 40 °C power reduction by 1.66 % per 1 K temperature increase	
Relative humidity	[%]	< 90 / condensation prohibited	
Installation height	[m über NN]	bis 2000, ab 1000 m Leistungsreduzierung um 1 % pro 100 m	
Storage and shipping temperature	[°C]	-20...+50	
Degree of soiling (in acc. with DIN EN 61800-5-1)		2	
Physical data			
Weight	[kg]	42,5	68/85
Dimensions h x w x d	[mm]	398,7 x 871.5 x 128	828 x 376 x 190

14.2 Part no.

Recuperation unit	Part no.
ZArec4C 013	357269
ZArec4C 026	357294
ZArec4C 039	357295

14.3 Allocation of ZArec4C to ZAdyn / ZETADYN frequency inverter

ZArec	ZAdyn/ZETADYN
4C 013	011-032
4C 026/039	032-074

14.4 EU declaration of conformity

- Translation -
(english)

A-KON16_05-GB
1614 Index 002

Manufacturer: ZIEHL-ABEGG SE
Heinz-Ziehl-Straße
74653 Künzelsau
Germany

The manufacturer shall bear sole responsibility for issuing this EU declaration of conformity.

Product description: Recuperation unit ZArec

Type: ZArec4C 013
ZArec4C 026
ZArec4C 039

The above mentioned products of this declaration fulfil all relevant provisions of the following Directives of the Union:

Low Voltage Directive 2014/35/EU

EMC Directive 2014/30/EU

The following harmonised standards have been used:

EN 61800-5-1:2007	Adjustable speed electrical power drive systems - Part 5-1: Safety requirements - Electrical, thermal and energy
EN 12015:2014	Electromagnetic compatibility- Productfamily standard for lifts, escalators and moving walks - Emission
EN 12016:2013	Electromagnetic compatibility- Productfamily standard for lifts, escalators and moving walks - Immunity

This declaration relates exclusively to the product in the state in which it was placed on the market, and excludes components which are added and/or operations carried out subsequently by the final user.

The authorised representative for the assembly of the technical file is:
Mr. Roland Hoppenstedt (see above for address).

Künzelsau, 20.04.2016
(location, date of issue)

ZIEHL-ABEGG SE
Werner Bundscherer
Director Drive Division
(name, function)



(signature)

ZIEHL-ABEGG SE
Roland Hoppenstedt
Technical Director Drive Division
(name, function)



(signature)

14.5 Index

B			
Basics	42	Memory Card menu	44
Block function	49	Menu and parameter navigation	41
C		Menu navigation	40
CAN menu	45	MMC recorder	45
Circuit suggestion ZAreC4C, ZAdyn4C and EVAC 3C	37	MMC-Recorder menu	45
Circuit suggestion, ZAreC4C and ZAdyn4C	34	Monitoring menu	43
Circuit suggestion, ZAreC4C and ZAdyn4C - 3~ evacuation	36	N	
Circuit suggestion, ZAreC4C and ZAdyn4C - UPS evacuation	35	Number of mains interruptions	44
Commissioning	7	Number of trips	44
Control transformer	26	O	
Control voltage	30	Operating hours	44
Controller menu	43	operating language	42
Copyright	5	operation and configuration	40
D		P	
Delete error memory	49	Parameter	42
Digital inputs	31	Pictographs	6
Digital outputs (X-IN-OUT)	32	Power section menu	45
Dimensions ZApad	38	Product safety	6
due diligence	7	R	
E		Readout the error memory	47
EMC-compatible installation	16	Recorder	45
Error list	44	S	
Exclusion of liability	5	Safety instructions	6
External brake resistor	27	Service	8
F		standby operation	52
fed back energy	46	start-up	41
Filter menu	43	Statistic menu	44
H		T	
Hazards	7	Target group	5
I		Technical data for ZAreC4C	4, 59
installation	9	Terminal positions	19
interventions	7	Transport	8
L		Z	
LCD & Password menu	42	ZA-Intern menu	45
LED	47	ZApad	38
M		ZApad control terminal	38
Mains connection	25		
maintenance	8		
Masc-Funktion	49		

Customer Service

phone +49 7940 16-308
fax +49 7940 16-249
drives-service@ziehl-abegg.com

Headquarters

ZIEHL-ABEGG SE
Heinz-Ziehl-Strasse · D-74653 Künzelsau
Germany
phone +49 (0) 7940 16-0 · fax +49 (0) 7940 16-249
drives@ziehl-abegg.de www.ziehl-abegg.com

