

**Start-up Guide for the Almega 2 / Magnetek HPV1000 connected to a geared machine.**  
**Switching the panel onto INSPECTION for the first time.**

***For all the below procedures please use site specific drawings for correct connections prior to wiring!***

Installation State:

1. The main 3 phase power, Motor, Braking resistors, Encoder (if closed loop), Motor Thermistor's, Brake and brake monitoring switches along with associated screening & earths are to be connected to the control panel. Motor wiring must be connected correctly ensuring that from the inverter the terminal U is connected to U on the motor, V to V & W to W otherwise this could cause irregularities in setup & control.
  - I. If no motor thermistors are present, then please connect the provided 1k resistor to terminal's THA/THB.
  - II. If closed loop then the encoder being used can now be connected to the inverter, please connect to the encoder card within the inverter and refer to the below table / manual for pin assignment. If no encoder is being fitted then this can be adjusted within drive settings.

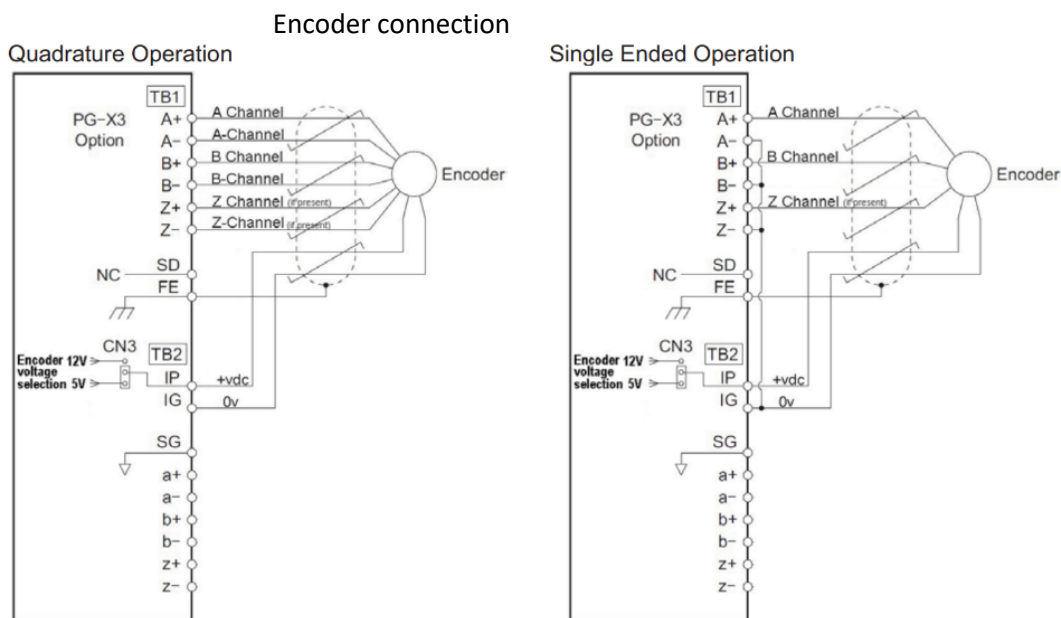

**Please note for the Encoder**

- *IP is the +VDC, and IG as the common.*
  - *The encoder voltage is selected via the jumper CN3 as either 5.5V or 12V.*
  - *Note that the encoder is wired into the upper-case terminals. The lower-case terminals are an output from the drive and will not necessarily be used.*
  - *If wired single ended, PG Card Detect (C1) must be Disabled.*
2. The safety and lock circuits must be in a state of continuity starting at OTL then following the site-specific drawings to the end which will be G4. If using Pre-locks, then the end will be G5.
  3. The test limits must be wired in, these are normally closed contacts, so continuity is needed between TUL to TU & (if fitted) TDL to TD.

Note: If Almega version is 4.15 or higher then INSTALLATION MODE can be set, this will deactivate the monitoring of THERMISTOR, PRE-FLIGHT CHECK, CAR GATE MONITORING, UMD FAILURE, ROPE MONITORING, BRAKE TEST MODE whilst working on INSPECTION CONTROL. This can be found in ENGINEERS SELECTION.

4. The door limits must be wired in. These are normally closed contacts so the processor should show limit OP closed and limit CL open.

If there are physical slowing limits in the shaft and NOT electronically via the positioning system:

5. These must be wired in. The connections for these are G2 to RSU & G2 to RSD, the processor should show RSU & RSD as Black when mid shaft and both top & bottom limits not activated.

If a panel test pendant is provided within the lift controller:

6. The panel test pendant MUST be switched to INSPECTION, then continuity must be made between terminals TTS to TS via the cartop controls test/normal switch. NOTE: CARE MUST BE TAKEN AS THIS IS THE CONNECTION FOR THE LIFT TO OPERATE IN NORMAL CONDITION.

**Please ensure that all wiring is connected correctly and checked prior to switching on.**

7. The panel can now be switched on.
8. Check the incoming 3 phase sequence is correct, if incorrect the phase failure will display a flashing LED.
9. Check that the TR contactor is NOT energised, this proves that the panel is not in the normal state.
10. (if fitted) The PIT ACCESS RESET PUSH needs to be pressed.

11. Pre-checks on the main lift viewer display:

- I. EMR,CARL,LANL, (PRE-Locks if fitted) are displayed as active.
- II. OP limit is shown as closed; CL limit is shown as open.
- III. If physical slowing limits both RSU & RSD are shown as not active (Black).
- IV. Within ENGINEERS SELECTION check the following are set to NO  
 UMD MON FAILURE  
 OVERTRAVEL FAULT  
 CAR GATE MONITORING

(Almega Ver 4.15 or higher will have INSTALLATION MODE which can be used as per above Note)

12. Drive settings:

- I. You will now need to verify the parameters entered in the drive match that of the motor data plate, please do not assume that these are already entered correctly. Enter these in the A5 menu.
- II. Enter / verify the following parameters:
  - CONTRACT CAR SPD (A1) *parameter should be the lift contract speed in m/s. This can be verified with a hand tachometer if required and adjusted if required.*
  - CONTRACT MTR SPD (A1) *parameter should be set to the RPM that is required to make the lift travel at contract car speed.*

**NOTE:** The above two parameters are utilized by the drive for many purposes regarding speed control of the lift, therefore its important these are set correctly prior to continuing any further.

- III. Enter the Line Voltage in the A4 menu:

INPUT VOLTAGE (A4) this parameter should be set to the measured incoming phase to phase voltage.

- IV. Please check the correct settings for the desired control mode:

Drive parameter	Open loop	Closed loop
U8 - Drive mode	Open Loop Vector	Closed Loop Vector
C3 - Relay M3/M4	BRAKE PICK	AUTOBRAKE

- V. The autotune can now be performed by navigating to the U9 menu. The drive has several options for autotuning the motor, however usually the motor will be roped, and so the 'Tune-No Rotate1' (Static) method will be used.  
 If the ropes are off, and the motor can turn freely, the 'Standard Tune' (Rotating) method can be used.

Navigate to the U9 menu and enter the following information:

- ‘Tune-No Rotate1’ (TUNING MODE SEL(U9))
- Motor Rated Power in kW (MTR RATED POWER(U9))
- Rated Voltage in V (RATED VOLTAGE(U9))
- Rated Current in A (RATED CURRENT(U9))
- Rated Frequency in Hz (RATED FREQUENCY (U9))
- Number of Poles (NUMBER OF POLES(U9))
- Rated Motor Speed\* (RATED SPEED (U9)) - *This is after slip, so NOT synchronous speed.*
- Encoder Pulses (ENCODER PPR (U9))
- No Load Current (NO-LOAD CURRENT(U9)) - *Enter 35% of the RATED MOTOR CURRENT entered above for 4 pole motors or 45% for a 6-pole motor.*

**\*Note** The rated motor rpm entered must equal what it can achieve at rated frequency, at full load and full speed. If synchronous speed is given on the data plate, a lower RPM must be entered. Table 2 gives an indication of typical motor rated rpm for lift applications.

Synchronous speed (50hz)	Rated motor Speed (rpm)	Number of motor poles	Typical No Load Current
1500	1480 - 1340	4	35%
1000	980 - 840	6	45%

Table 2: Synchronous/Asynchronous Motor Speeds & Motor Poles Reference for 50Hz

Once the above information has been entered and the bottom of the menu is reached the screen will display: ‘Auto-tuning. Waiting for command – Tune Ready? Give Run/Hit Enter’. At this point **DO NOT** press any keypad buttons.

Using your inspection controls, **PRESS AND HOLD** the buttons to run the lift in the **UP DIRECTION** (the lift will not move; however the tune will begin) If the drive has control of the motor contactors they will now pull in and the tune will begin.

During this process, the drive will display motor speed and motor current for reference.

Once complete the drive will display “END Tune Successful”. The test run UP button can now be released.

13. The lift should now be able to move on INSPECTION CONTROL, Run the drive in low speed inspection mode and...

- Start with default value of 2 for INERTIA (A1)
- Verify encoder polarity. The motor phasing should match the encoder phasing. If you experience Speed Dev Flt/ PGO Fault the phasing may be incorrect - this can be reversed changing ENCODER CONNECT (C1) between Forward and Reverse
- Verify correct lift car direction. This can be reversed by changing both the MOTOR ROTATION and ENCODER CONNECT (C1) parameters.
- If the lift fails to run in Open loop vector change U8 Drive mode to VF CONTROL, carry out another auto tune before attempting to move again on inspection.

*If needed please contact [technical@lestercontrols.co.uk](mailto:technical@lestercontrols.co.uk) where someone will be able to assist.*