

Distributed by:

Lift.it S.r.l.
Tel. +390332464108
Fax +39033460578
e-mail: liftit@virgilio.it

AACS

digistart

3DS30 2X

CE

Release 1.1 28th april 2006

1 - Introduction

The digital SOFTSTARTER 3DS30 2X is planned to provide a progressive starting with three-phase induction motors, and to reduce the values of the current and of the motor torque. All the devices have an adjustable acceleration ramp, with adjustable pedestal (starting mechanical stress and motor torque), to allow the greatest flexibility in the use of each plant.

The devices are simply inserted between the remote control switches and the motor. A relay contact is available to drive the recirculation electro-valve or a by-pass contactor or to give a reached speed signal.

The control circuit is galvanic isolated from the power circuit.

1.1 – CE Marking

The CE Marking is in accordance with the law 89/336/CEE (and following amendments), regarding the ELECTROMAGNETIC COMPATIBILITY on the base of tests made by QUALIFIED ORGANIZATION.

2 – Electric Installation

BEFORE MAKING ANY CONNECTION OR ANY SETTING OF THE SOFTSTARTER 3DS30, PLEASE READ THIS MANUAL COMPLETELY AND CAREFULLY. FEED THE SOFTSTARTER ONLY WITH THE CONNECTED COVER. DO NOT REMOVE IT WHEN THE DEVICE IS FEEDED.

- 2.1 Check that the main device voltage is like the network voltage.
- 2.2 Connect the motor, the motive power and the ground as in the following diagrams (picture 1, 2, 3, 4)
- 2.3 Make the control circuit considering that:
 - a) To have a start and stop combining with the power supply and the network disconnection, connect together the terminals 11 – 12.
 - b) The internal relay RUN can be used to open the main contactors in order to save the power contactor. In this way the SOFTSTARTER allows the passage of the current after the closure of the main contacts and it opens them only with a complete lowering ramp and 0 current, avoiding the formation of the electric arc.
- 2.4 Try the working of the system operating the contactors by hand or making a maintenance call, checking for the right rotation sense of the motor and its progressive start. In case the motor rotation sense is not correct, invert the phase R with the phase S.
If the motor stands still, verify that:
 - The PWR Led (inserted network) is ON and the STATUS Led flashes with a green light.
 - The contact between terminal 11 – 12 is closed (by a jumper or a relay contact) and the START Led is ON.
- 2.5 Make a call from the control cabinet: the system has to start without important delays compared to the direct starting and, once the motor reaches its full speed, the TOP OF RAMP relay must commute.
This relay contact is available:
 - To drive the possible starting electro-valve;
 - To drive the possible BY-PASS contactor of SOFTSTARTER.
- 2.6 The SOFTSTARTER leaves the factory tested and adjusted in order to have a starting time of about one second, a current limit equal to its maximum output current, and a time of deceleration equal to 0. The ILIM trimmer can be rotated in anticlockwise sense in order to reduce the starting current and to reach the desired value; or use the ACC trimmer rotating it in clockwise sense in order to increase the starting time.

2.7-Softstarter connected in line below the contactors

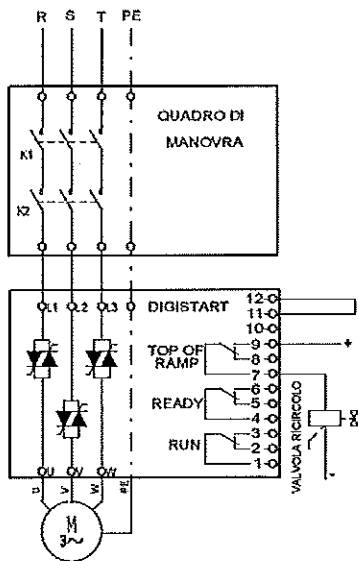

Pic. 1

2.8 Softstarter connected in line above the contactors

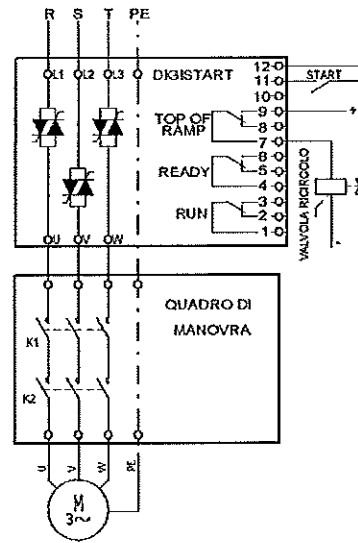

Pic. 2

2.7- Softstarter connected in phase below the contactors

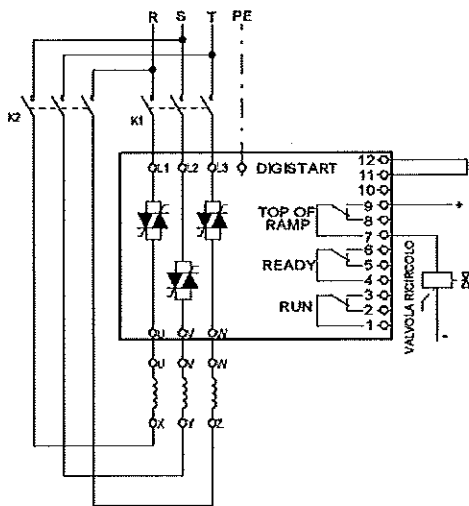

Pic. 3

2.8- Softstarter connected in phase above the contactors

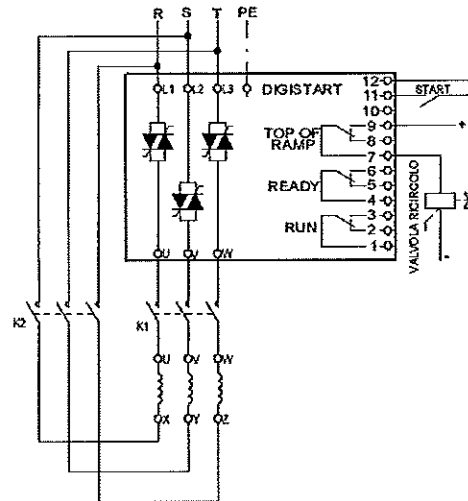

Pic. 4

The pictures 3 and 4 show the use of the SOFTSTARTER inserted in the triangle. In line at 380V, the motor will be 660 star / 380 triangle.

With this connection the SOFTSTARTER and the contactors have a current 1,73 times lower than that in line.

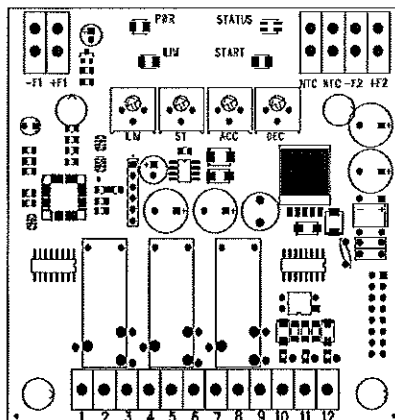

Pict. 5 – Silk-screen process of the control card

3 - Adjustments

There are 4 trimmers to set the SOFTSTARTER to an optimal system performance according to the characteristics of each system.

- Rotating ILIM trimmer, the max current of the SOFTSTARTER can be set: remember that limiting the current, the torque of the motor is reduced and the starting time increases.
- Using the ST trimmer, the starting voltage applied to the motor can be adjusted, and so the starting torque (not linearly). It has to be tuned so that the motor starts running immediately, but pay attention because a too high setting avoids the SOFT effect.
- Using the ACC trimmer, the inclination of the acceleration ramp can be adjusted, working on the time used to pass from initial voltage to the output voltage (rotating the trimmer in clockwise sense, the acceleration time increases).
- Using the DEC trimmer, the inclination of the deceleration ramp can be adjusted working on the time used to pass from the output voltage to the initial voltage (rotating the trimmer in clockwise sense, the deceleration time increases). Rotating it completely in anticlockwise sense, the deceleration can be excluded.

ATTENTION

In hydraulic lifts application, the motor starting time is about 1 sec. for a current as high as twice the rated current.

THE MINIMUM STARTING CURRENT IS EQUAL TO THE RATED CURRENT, but in this case the starting time becomes about 5-10 seconds.

ACC	=	Adjustment time		0,6 ÷ 5 sec.
ILIM	=	Starter current limit	3DS30 21	max 50A
			3DS30 22	max 90A
			3DS30 23	max 120A
			3DS30 24	max 150A
			3DS30 26	max 200A
ST	=	Starting pedestal adjustment (% of rated voltage)		25 ÷ 75
DEC	=	Time adjustment		0 / 0,3 ÷ 5 sec.

The DIGISTART has no internal protection against short circuits of the motor. For protection of power part, ultra-fast fuses need to be included (one for each phase) and measured according to the starter size.

4 – General technical information

In line included:

Model	I _{nom} A	I _{avv} A	Power		Dimensions
			KW a 230V	KW a 400V	
3DS30 21	25	50	5,8	10,0	100 x 280 x 148 mm
3DS30 22	45	90	10,5	18,5	100 x 280 x 148 mm
3DS30 23	60	120	13,5	24,0	100 x 280 x 148 mm
3DS30 24	75	150	17,3	30,0	100 x 280 x 148 mm
3DS30 26	100	200	23,0	40,0	100 x 280 x 148 mm

In phase included into the triangle:

Model	I _{nom} A	I _{avv} A	Power		Dimensions
			KW a 230V	KW a 400V	
3DS30 21	25	50	10,0	17,3	100 x 280 x 148 mm
3DS30 22	45	90	18,5	32,0	100 x 280 x 148 mm
3DS30 23	60	120	24,0	41,5	100 x 280 x 148 mm
3DS30 24	75	150	30,0	52,0	100 x 280 x 148 mm
3DS30 26	100	200	40,0	69,3	100 x 280 x 148 mm

Main power supply:	Selectable with jumper ($\pm 10\%$)	3 x 400V 3 x 230V
Frequency:	50 ÷ 60 Hz ($\pm 10\%$) (automatic setting)	
Temperature:	0 ÷ 40 °C	
Altitude:	1000 m slm. - 1% every 100 m. over	
Protection:	IP00	
Weight:	Kg 3,8	
Cooling system:	- Natural cooling using a dissipator included in the container till size 23 - Forced with temperature control for higher sizes	
Control power supply:	Derived from the main power	
Control circuit:	Digital by microprocessor	
Starts/ hour:	60	
Starting voltage:	25% ÷ 75% V continually adjustable	
Starting time:	0,6 ÷ 5 sec continually adjustable	
Failure detection:	Lack of motor phase, lack of line voltage, defective thyristor	
Attention:	The control circuit is galvanic isolated from the power circuit .	

5 – Signals – Terminal board

LED signals:

- Power On: signalises presence of power supply
- Status: two-colour signal of the device status
- Current Limit: it lights when current is being limited to the ILIM value during start-up
- Start: it lights when a starting command is given

Output Relay:

- Top of Ramp: it closes when the output reaches the full voltage; it can be used to drive the recirculation electro-valve or a by-pass contactor.
- Ready Relay: It commutates when the motor is correctly running. It can be used for external indications or to self-keep the line contactor, so that the contactor itself becomes de-excited when a protection comes.
- Run Relay: It closes when the motor is feeded; it can be used to drive the de-excitation of the main contactors and to open the loud at current 0
- Relay contacts: 8 A 250 Vac AC1

6 – FAST GUIDE DIGISTART 3DS30 2X

LED	Signals	Conditions	Actions
All	OFF	No power supply	Check the line (L1,L2,L3) and correct jumper selection
PWR Status	ON Slow green light lamping	Digistart ready to start	
PWR Status Start	ON Red light lamping	Thyristors failure or lack of motor phases	Check the motor connection (U,V,W)
PWR Status Start	ON Fast green light lamping	Digistart is accelerating	
PWR Status Start ILIM	ON Fast green light lamping ON ON	Current limiter is working, the max voltage is not reached yet	
PWR Status Start	ON Green ON	Digistart at regime. Relay "Top of Ramp" closed.	
PWR Status	ON Fast green light lamping	Digistart is decelerating	

Start | OFF

7 – Control Circuit Schematics

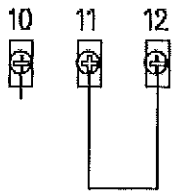

Pict. 6
Automatic working

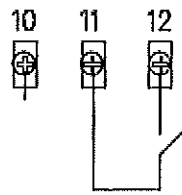

Pict. 7
Working with
internal auxiliary
voltage through NO
contact

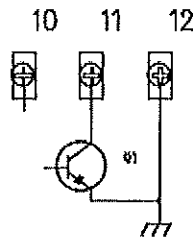

Pict. 8
Working with
internal auxiliary
voltage through PNP
transistor

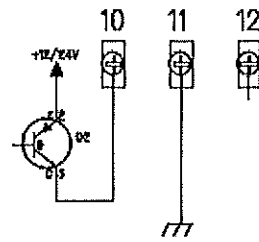

Pict. 9
Working with
external auxiliary
voltage through PNP
transistor

8 – Mechanical Dimensions

